

# Aquablend 2000 Thermostatic Mixing Valve

## ATM713

Aquablend's technology provides superior control, under changing pressure and temperature conditions as well as at ambient start up when scald protection is needed most. The proven performance, reliability and low 'whole of life' cost makes Aquablend a popular choice with specifiers, engineers, plumbers and property owners.

The Aquablend 2000 is the health care preferred valve, particularly in NSW with NSW Health approval. The polished chrome body finish is ideal for exposed installations and as with all the Aquablend range, lockable cabinets are available for added security.

### FEATURES

- Standards Licensed to AS4032.1 - Thermostatic Mixing Valves
- Scald and thermal shock protection with rapid thermal shut-off should either the cold or hot water supply fail.
- Highly responsive temperature control, maintaining outlet temperature within +/- 2°C under changing inlet temperature and pressure conditions
- Delivers excellent flow, operating at a minimum pressure of 20kPa
- Supplied complete with isolating valves, non-return valves and dual stage strainers incorporating temperature/pressure test ports
- Comprehensive Technical Manual supplied with every TMV
- Flexible installation - can be upside down or sideways, inlet and outlet connections may be rotated to suit pipework design

- OPTIONS** Standard 3-hole boxes **ATMS216**  
 Cold water by-pass 4-hole boxes **ATMS219**  
 Smart Flow™ TMV Monitoring & Control System  
 For more options contact your Enware representative

### Product Codes

**ATM713** 20mm F Inlet 20mm MI Outlet

### Technical Information

Mixed Temperature Range	38° to 50°C
Dynamic Inlet Pressures	Min 20kPa Max 500kPa For optimum operation it is recommended that the hot and cold water supply pressures be balanced within +/- 10%
Static Inlet Pressures	Maximum 1600kPa for testing purposes/system commissioning
Inlet size	3/4" BSP Female
Outlet size	3/4" BSP Male
Inlet Temperatures	Cold Supply: Min-5°C Max-30°C Hot Supply: Min-55°C Max-90°C Hot to Mix temperature differential required for stable operation is Minimum: 10°C
Inlet Pressure Ratio	H - PL = H <sub>1</sub> C - PL = C <sub>1</sub> H <sub>1</sub> : C <sub>1</sub> = Max 10:1 C <sub>1</sub> : H <sub>1</sub> = Max 10:1 H = Hot inlet pressure C = Cold inlet pressure PL = Pressure Loss
Flow Rates	38 lpm@300kPa pressure loss
Minimum Flow Rate for stable outlet temperature	2 lpm (4 lpm recommended for optimum performance)

Enware tap ware must be installed in accordance with the provisions of AS/NZS 3500. Installations not complying with AS/NZS 3500 may void the product and performance warranty provisions.



### HEADLOSS CHARACTERISTICS OF AQUABLEND 2000

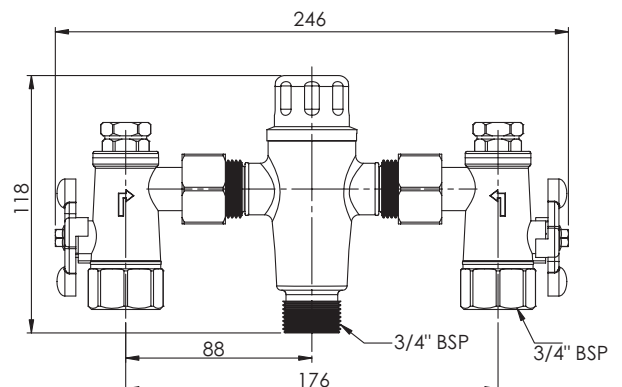
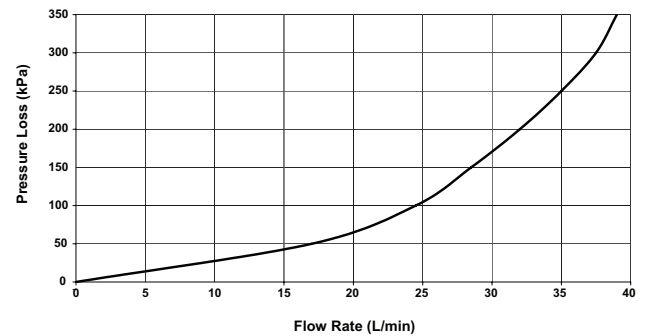

Version: Feb 18

Call 1300 369 273  
[www.enware.com.au](http://www.enware.com.au)



Enware Australia Pty Limited  
 9 Endeavour Rd Caringbah NSW 2229 Australia  
 Ph: 02 8536 4000 info@enware.com.au