

Tempering Valve Assemblies

TVA

TEMPERING VALVE ASSEMBLIES, TVA (Standard - yellow cap)

Suitable for storage hot water systems.



TVA15C-i

FEATURES

- Maximum hot water supply temperature 85°C.
- More accurate control: $\pm 3^{\circ}\text{C}$ from set temperature (to AS4032.2)
- Fast response to pressure fluctuations.
- Forged DR bronze body.
- Advanced polymer components for greater resistance to calcium deposits.
- Integral 60 mesh stainless steel line strainers.
- Integral non return valves.
- Stainless steel springs.
- O-ring seal inlet union connectors complete with nuts and olives.
- Tamper proof adjustment.
- Special adjusting tool supplied moulded into valve cap.
- Seasonal adjustments not required.
- Factory set at 50°C (must be commissioned onsite by installer).
- Water Mark Certification – License No. 20137.



INSULATION
included in
accordance
with AS3500

Tempering Valve Assemblies

TVA

TVA SPECIFICATIONS

MODEL	DN SIZE	A	B	C	D
TVA15C- <i>i</i>	15mm	144	58	113	67
TVA20C- <i>i</i>	20mm	147	58	112	66

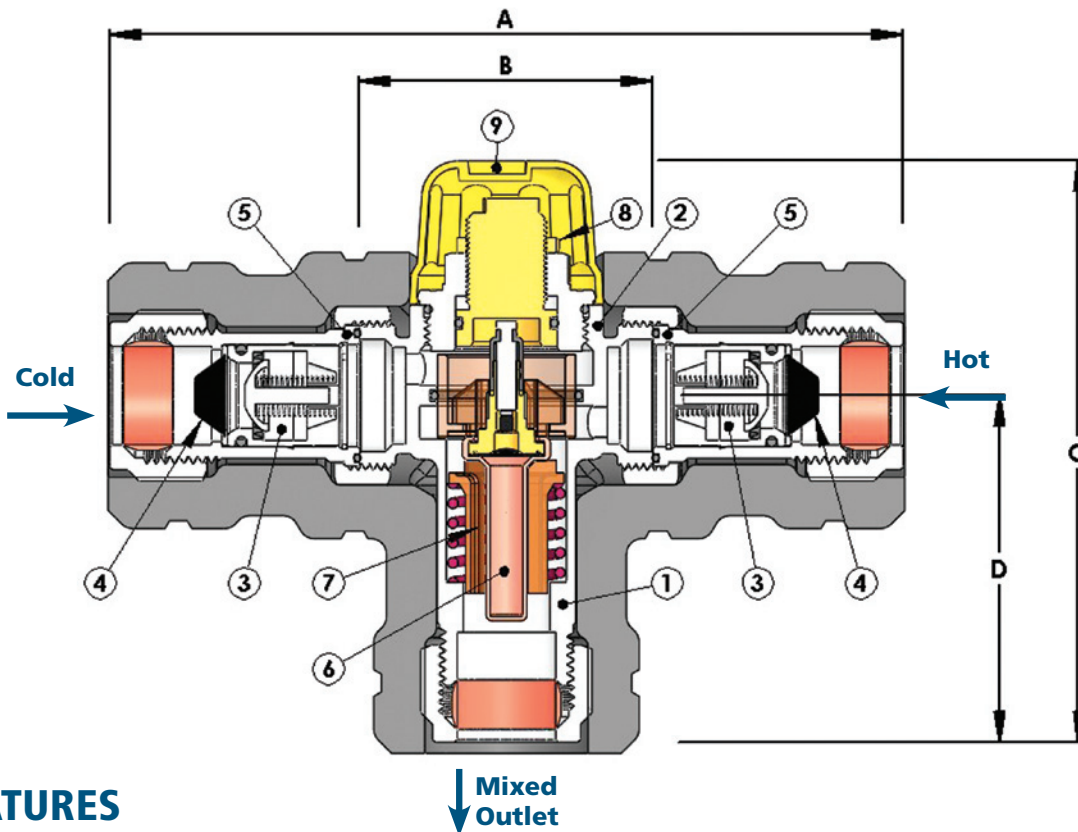

FEATURES

1. Forged DR brass body.
2. Compact body design.
3. Integral non return valves in all models to enhance flow through the valve.
4. Filters to prevent debris entering the valve.
5. O-ring seal inlet union connectors complete with nuts and olives.
6. Compact high performance probe provides smooth consistent hot water.
7. Water flow directors inside the valve prevent turbulence and enhance flow.
8. Locking mechanism to prevent tampering.
9. Integrated adjustment tool in cap - no spanners to go missing.

FIT & ROTATE CAP ANTI-CLOCKWISE TO INCREASE TEMPERATURE SETTING

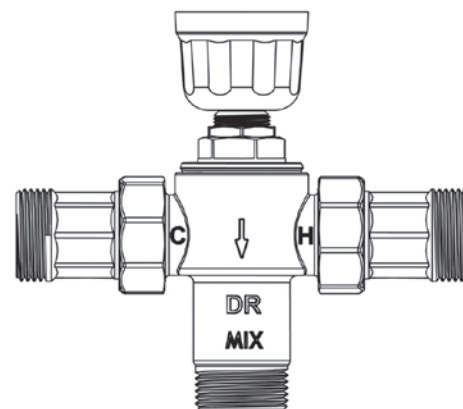

Suitable for Storage Hot Water Systems

TVA15C-i AND TVA20C-i SPECIFICATIONS

Cold Water supply temperature:	5°C – 25°C
Hot Water supply temperature:	65°C – 85°C
Adjustable outlet temperature:	40°C – 50°C
Factory set temperature:	50°C normal (must be commissioned onsite by installer)
Accuracy of outlet temperature:	±3°C – tested to AS4032.2
Min. temperature differential (between hot supply and outlet temperature):	15°C
Supply pressure, static:	1400kPa max.
Supply pressure, dynamic:	500kPa max.
Pressure supply imbalance, dynamic (at time of commissioning):	2:1 max.
Max. permitted pressure variation in either supply in order to control outlet temperature to ±3°C (from supply pressure at commissioning):	±10% max.
Flow rate min.:	4 litres/min



TVA15C-i

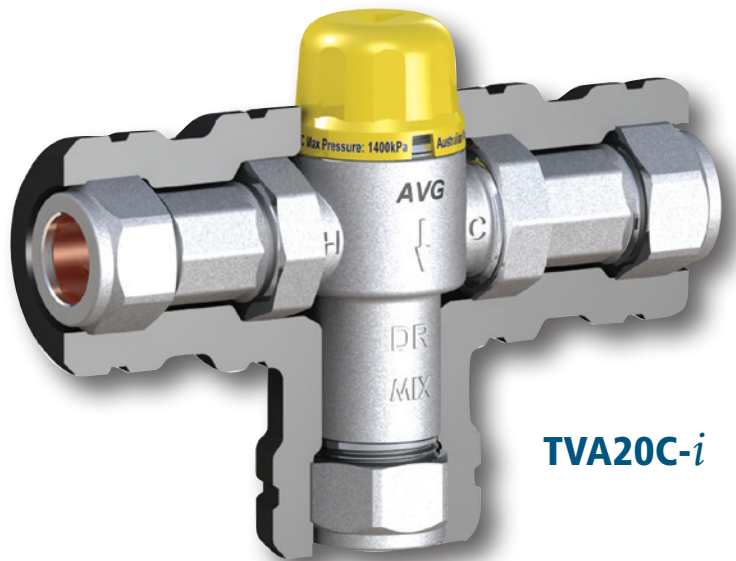
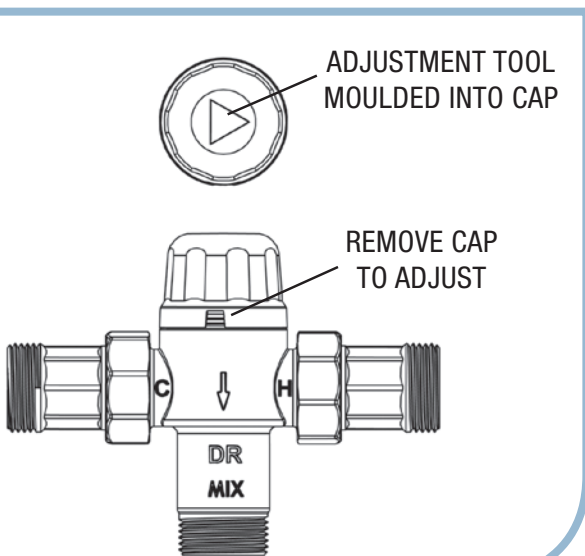
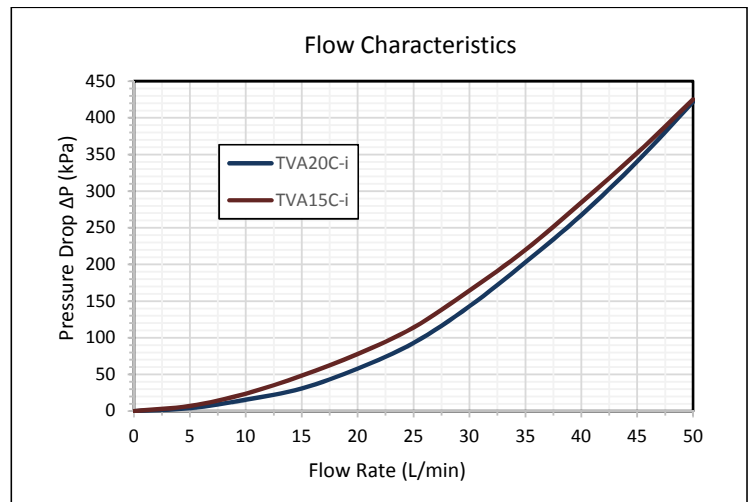

TVA20C-i

Tempering Valve Assemblies

TVA

INSTALLATION

The Tempering Valve must be installed by a licensed plumber and in accordance with AS/NZS3500 National Plumbing and Drainage Code, relevant local government requirements and the following:

- Tempering Valve must be fitted in accordance with the instructions supplied with the valve.
- It is recommended that isolating valves are fitted immediately upstream of both hot and cold inlets to the tempering valve. This allows convenient access to isolate the tempering valve in the event that the strainers need to be cleaned.
- It is recommended that the tempering valve be installed as close as possible to the point of use, however it may be fitted anywhere on the hot water supply line.
- When the tempering valve is fitted at the point of use, there must be a minimum 1 metre pipe run between the valve mixed water outlet connection and the tap.

The tempering valve must be installed by a licensed plumber and in accordance with AS/NZS 3500 building code and relevant local requirements and the following manufacturer's instructions.

SYSTEM SUPPLY PRESSURES

Tempering valves provide optimum performance when installed with hot and cold water supplies of equal dynamic pressure, i.e. with the water flowing. (The static supply pressures often give no indication of the dynamic supply pressures).

It is recommended that the hot and cold water supplies to each tempering valve be controlled via their own pressure control valve. In most domestic installations it should be possible to fit one control valve at the property boundary to control pressure to the whole site. For commercial installation it is recommended to fit a pressure control valve on each inlet to the tempering valve.

TYPICAL CONTROLLED PRESSURE HOT WATER SYSTEM INSTALLATION

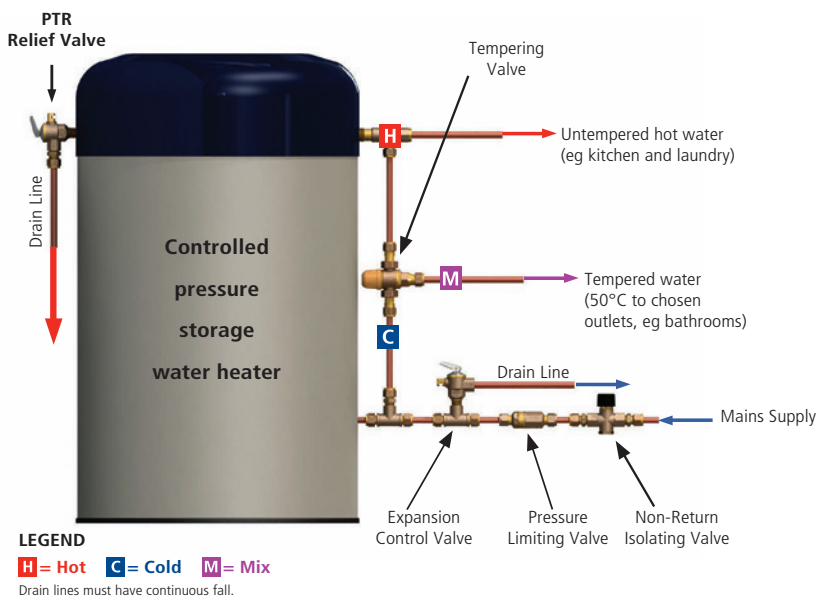

Caution: Water escaping from the drain line may be hot and could cause scalding. This valve is a Safety Valve. Excessive discharge from the drain line or operation of the small auxiliary relief valve opposite the drain can mean a malfunction within the system. Switch off the energy source and call a plumber or service person.

The tempering valve may be installed at the point of use, but there must be a minimum 1 metre pipe run between the valve mixed water outlet connection and the tap.

TEMPERATURE ADJUSTMENT

- Prior to adjusting the tempering valve it is necessary for the hot water heater to be switched on and delivering hot water at the recommended temperature. If the water heater has an adjustable thermostat it is recommended that the thermostat be set to 65°C. Ensure that the water heater has reached the set temperature before commissioning the tempering valve.
- Test the mixed water temperature at the nearest outlet being supplied by the tempering valve. The tap should be opened to allow a flow rate of at least four (4) litres/minute.
- A thermometer must be used to ensure the correct mixed water temperature is achieved.

- Allow the water to run for at least one minute to ensure the mixed water temperature has settled after each adjustment.
- To adjust the mixed outlet temperature of the tempering valve the cap should be removed to gain access to the adjusting spindle. Using the special tool moulded into the top of the cap rotate the adjusting spindle to achieve the required temperature. The spindle should be rotated - clock wise to reduce the temperature, anti-clock wise to increase the temperature - until the desired temperature is reached. See adjustment diagram provided with the valve.
- Once the required temperature is achieved the cap should be snapped onto the valve to prevent accidental adjustment.
- When the tempering valve has been commissioned, the commissioning label must be completed by the installer and affixed to the water heater in a prominent position, (or other suitable position or as specified by the Local Authority).

Installation Instructions