

Type 100 Wall Mounted Fountain Female 15mm

BUB219L

A wall mounted self closing fountain for dispensing drinking water generally used above a basin or in multiples in line above a drinking trough. The fixed metal mouth guard prevents unnecessary user contact with the water outlet. An adjustable flow control allows the height of the drinking water stream to be set according to site supply conditions. The two fixing screw holes in the wall flange allows the fountain to be secured in place.

FEATURES

- Vandal resistant design
- Self-closing mechanism
- DR Brass construction
- Integral adjustable flow regulator

OPTIONS

- Push Button - refer to BUB219B
- Cam Handle - refer to BUB219C

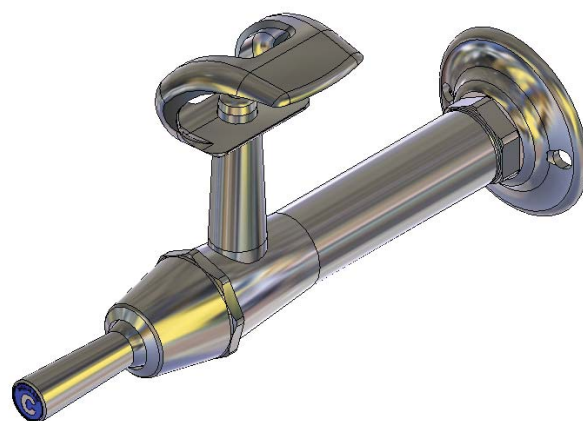

Product Codes

BUB219L Lever Handle

Technical Information

Inlet Connection	15 mm (1/2") BSP
Working Pressure Range	30 - 1200 kPa
Recommended Pressure	100 - 500 kPa
Flow Rate	Supplied standard 8 l/minute with Enware Outlet. Not included under this code.
Operating Temperature Range	0-85°C
Recommended Temperature Range	5-30°C

Enware tapware must be installed in accordance with the provisions of AS/NZS3500 and any relevant local regulations. Installations not complying with AS/NZS3500 may void the product and performance warranty provisions.
The performance of Enware AS/NZS 3718 tapware, in many cases, exceeds the plumbing system design requirements of the Plumbing Code of Australia and AS/NZS 3500.

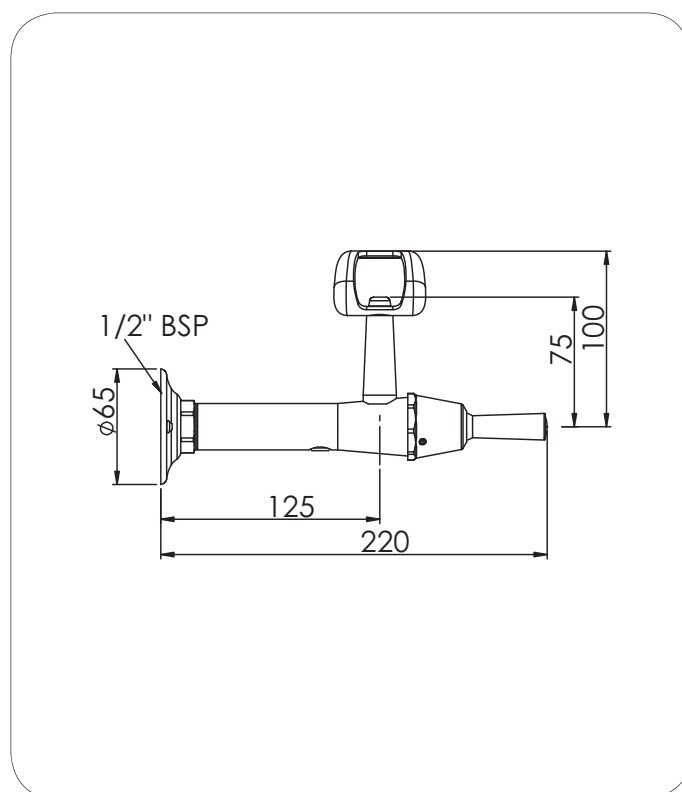

Version: DEC12

Call 1300 369 273
www.enware.com

Enware Australia Pty Limited
9 Endeavour Rd Caringbah NSW 2229 Australia
Ph: +61 2 8556 4000 Fax: +61 2 8556 4055

