

PART NO.	L	FINISH
SCS-C-600-19	600	POLISHED
SCS-C-900-19	900	POLISHED

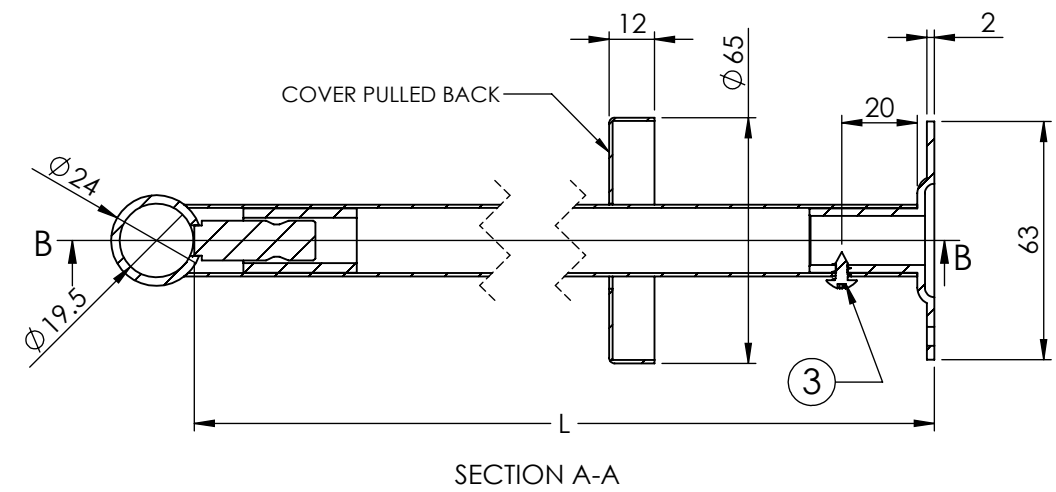

ITEM NO.	PART NUMBER	DESCRIPTION	QTY.
1	SC90900-F-19	FLANGE	1
2	SC90900-C-19	COVER	1
3	SCS-4-45	SCREW-C/SUNK-4MMX45MM	3
4	WP-6-30	WALL PLUG-6MMX30MM	3
5	SDH-3-10	SCREW-DOME HEAD-3MMX10MM	1
6	SCS900-19-1	SUPPORT	1
7	SS-M5-5	SET SCREW-M5X5MM	2
8	SCS900-19-3	EYE	1

DRAWN	B DOOLAN	17/06/2015	CAT NO:	<h1>SCS-C-19</h1>	REV: <b>A</b>
CHK'D	U WAUGE	17/06/2015			
MATERIAL	304 STAINLESS STEEL		DESCRIPTION:	<h2>CEILING SUPPORT- CONCEALED FLANGE-19MM</h2>	
FINISH	POLISHED				
WEIGHT			<p><b>EMROWARE™</b> www.emro.com.au</p> <p><small>This drawing has been made with due care and attention however Emro do not accept any responsibility for variations. This drawing and information contained is the property of Emro and cannot be used without their consent.</small></p>		