

Please check actual product in box for bracket type used (Hardwire)

ARCH 700

LED MIRROR

PRODUCT CODE
 GAR70D

SPECIFICATIONS

WIDTH	700mm
HEIGHT	1000mm
DEPTH	35mm
WEIGHT	11kg
ORIENTATION	Portrait

FEATURES

- Copper Free Mirror
- LED Lighting
(Adjustable Colour Temperature)
- Touch Sensor
- Demister with 1 Hour Auto Cut-off

LIGHTING SPECIFICATIONS

CCT	2700K - 6500K
CRI	>80

INSTALLATION

- Wall mount
- Hardwire
- Input voltage: 220-240v 50Hz

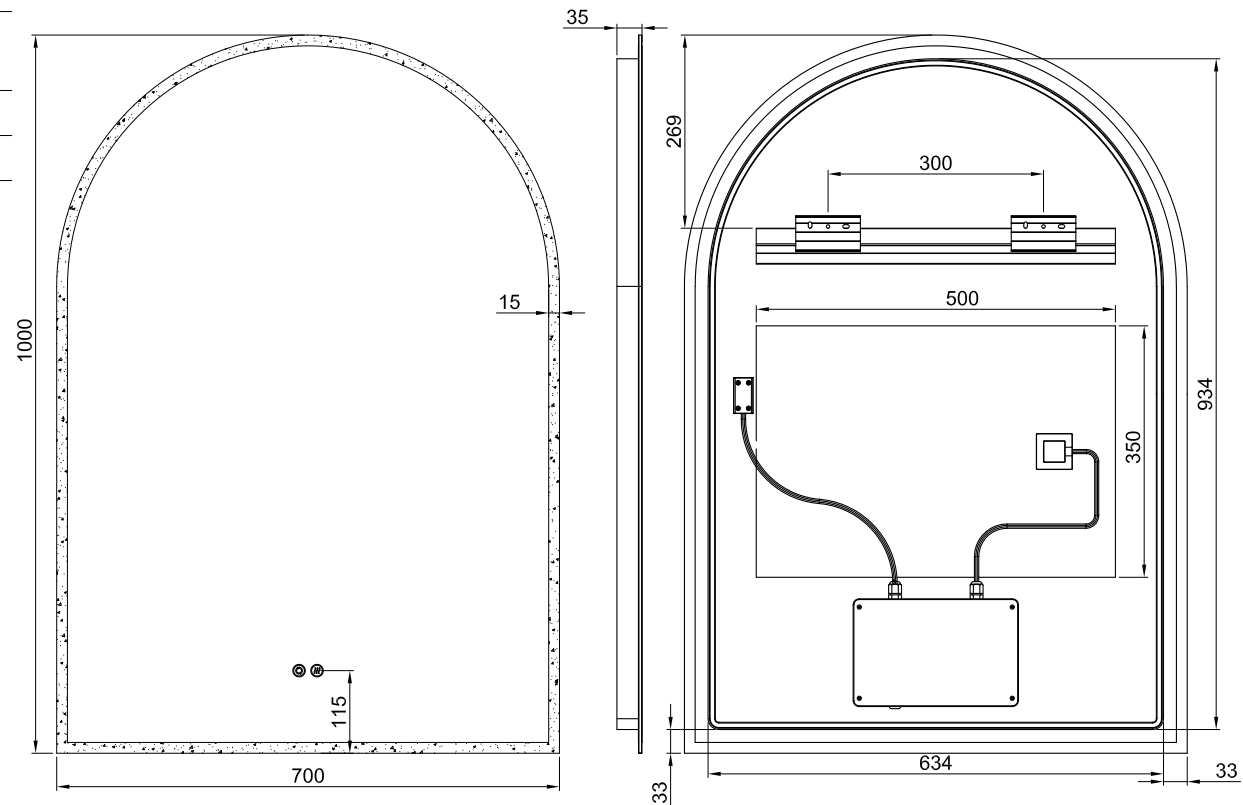

Disclaimer: All LED Products requiring hardwiring must be installed by a licensed electrician in accordance with local regulations. Sizes are in mm and nominal and should be checked prior to installation. Actual colours may vary so please check colour samples before ordering. Installation is acceptance of our products. Installation of faulty, warped, chipped or damaged products will void our warranty.

Please check actual product in box for bracket type used (Plug/Hardwire)

ARCH 700

LED MIRROR

PRODUCT CODE
GAR70D

SPECIFICATIONS

WIDTH	700mm
HEIGHT	1000mm
DEPTH	35mm
WEIGHT	11kg
ORIENTATION	Portrait

FEATURES

- Copper Free Mirror
- LED Lighting (Adjustable Colour Temperature)
- Touch Sensor
- Demister with 1 Hour Auto Cut-off

LIGHTING SPECIFICATIONS

CCT	2700K - 6500K
CRI	>80

INSTALLATION

- Wall mount
- Plug or Hardwire
- Input voltage: 220-240v 50Hz

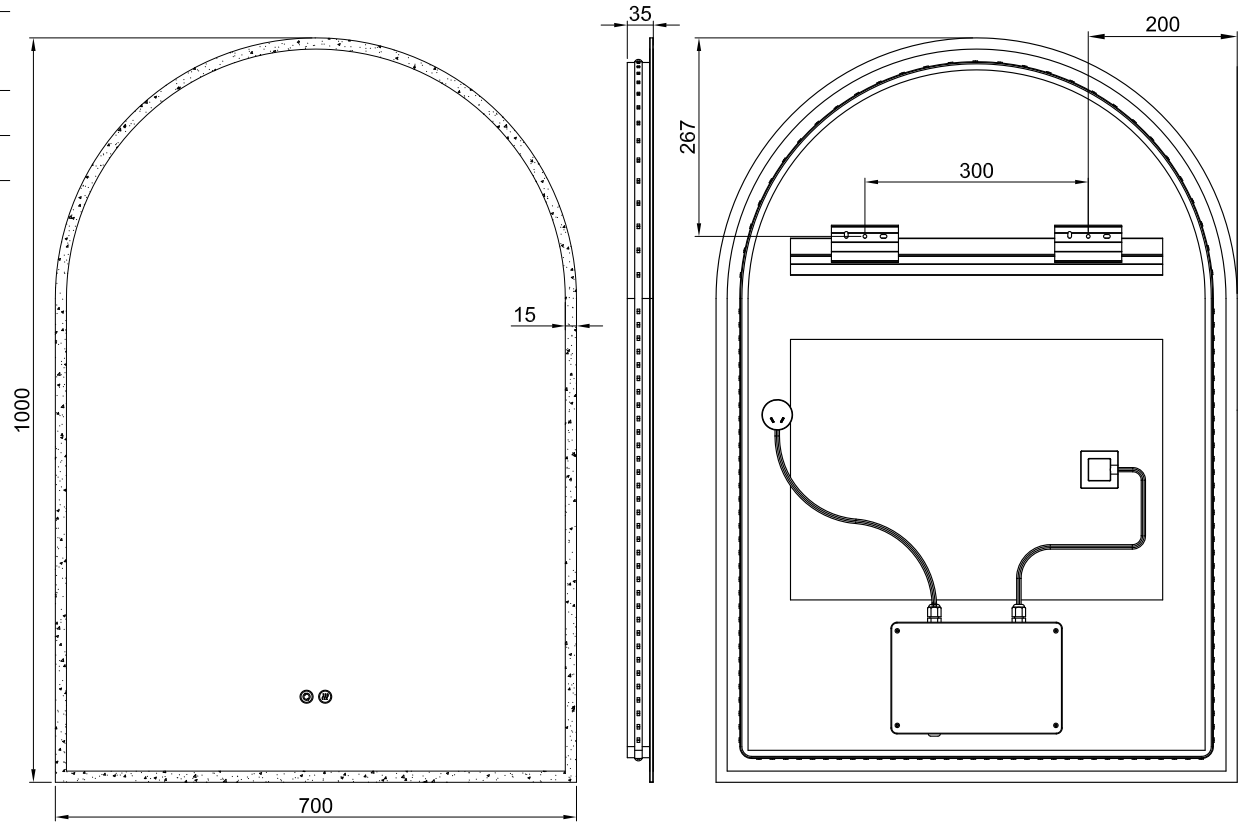

Disclaimer: All LED Products requiring hardwiring must be installed by a licensed electrician in accordance with local regulations. Sizes are in mm and nominal and should be checked prior to installation. Actual colours may vary so please check colour samples before ordering. Installation is acceptance of our products. Installation of faulty, warped, chipped or damaged products will void our warranty.

Please check actual product in box for bracket type used (Hardwire)

ARCH 700

LED MIRROR WITH ALUMINIUM FRAME

SPECIFICATIONS

WIDTH	705mm
HEIGHT	1005mm
DEPTH	40mm
WEIGHT	11kg
ORIENTATION	Portrait

LIGHTING SPECIFICATIONS

CCT	2700K - 6500K
CRI	>80

INSTALLATION

Wall mount
Hardwire
Input voltage: 220-240v 50Hz

FEATURES

Copper Free Mirror
LED Lighting (Adjustable Colour Temperature)
Touch Sensor
Demister with 1 Hour Auto Cut-off

FINISH		PRODUCT CODE
Brushed Brass		GAR70D-BB
Brushed Nickel		GAR70D-BN
Gun Metal		GAR70D-GM
Matte Black		GAR70D-MB
Matte White		GAR70D-MW

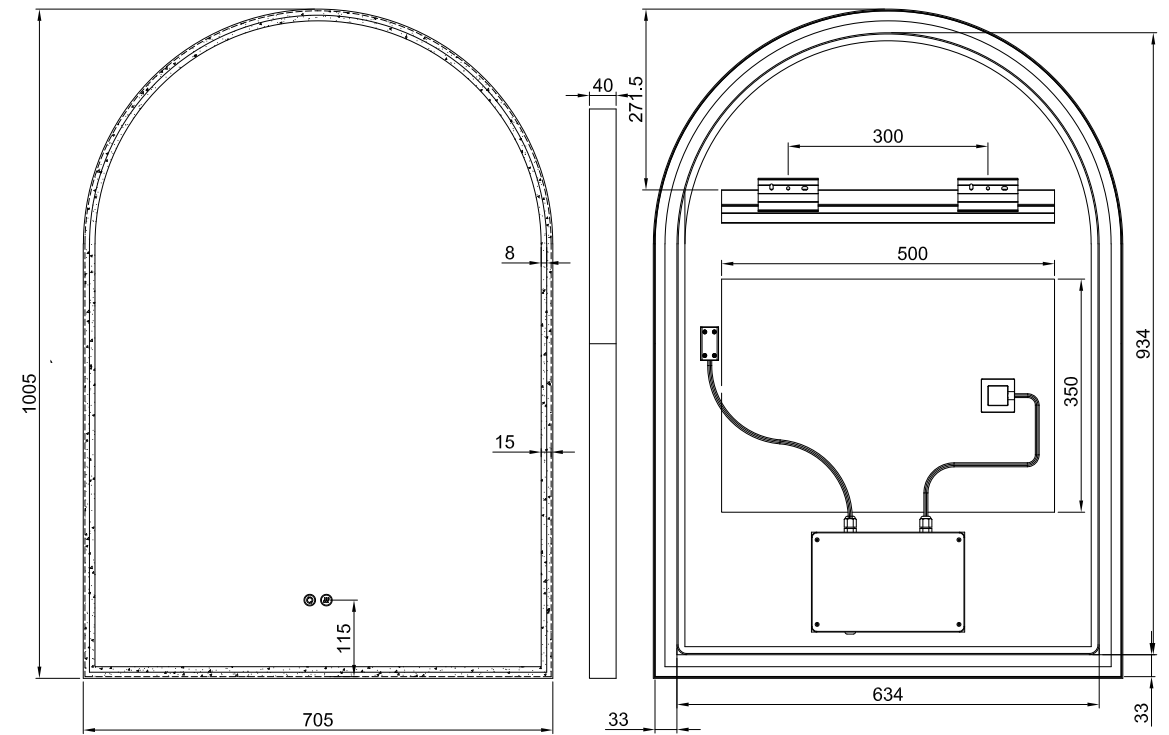

Disclaimer: All LED Products requiring hardwiring must be installed by a licensed electrician in accordance with local regulations. Sizes are in mm and nominal and should be checked prior to installation. Actual colours may vary so please check colour samples before ordering. Installation is acceptance of our products. Installation of faulty, warped, chipped or damaged products will void our warranty.

Please check actual product in box for bracket type used (Plug/Hardwire)

ARCH 700

LED MIRROR WITH ALUMINIUM FRAME

SPECIFICATIONS

WIDTH	705mm
HEIGHT	1005mm
DEPTH	40mm
WEIGHT	11kg
ORIENTATION	Portrait

LIGHTING SPECIFICATIONS

CCT	2700K - 6500K
CRI	>80

INSTALLATION

Wall mount
Plug or Hardwire
Input voltage: 220-240v 50Hz

FEATURES

Copper Free Mirror
LED Lighting (Adjustable Colour Temperature)
Touch Sensor
Demister with 1 Hour Auto Cut-off

FINISH		PRODUCT CODE
Brushed Brass		GAR70D-BB
Brushed Nickel		GAR70D-BN
Gun Metal		GAR70D-GM
Matte Black		GAR70D-MB
Matte White		GAR70D-MW

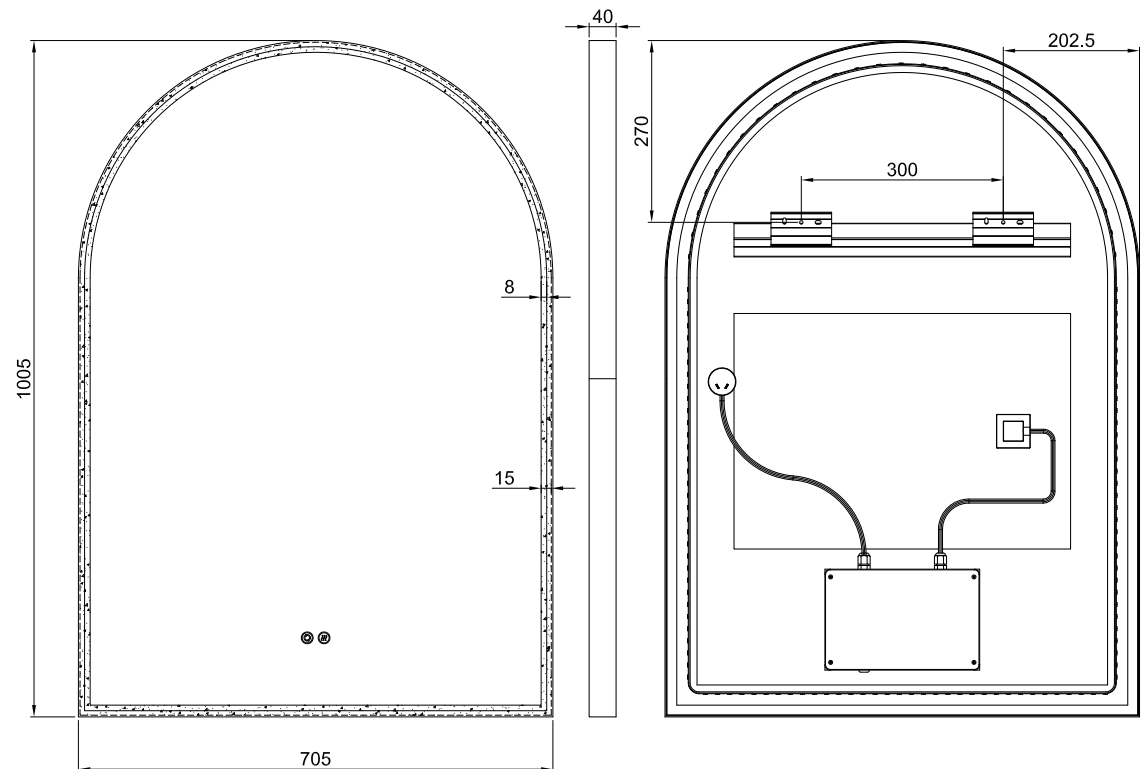

Disclaimer: All LED Products requiring hardwiring must be installed by a licensed electrician in accordance with local regulations. Sizes are in mm and nominal and should be checked prior to installation. Actual colours may vary so please check colour samples before ordering. Installation is acceptance of our products. Installation of faulty, warped, chipped or damaged products will void our warranty.