

Victaulic® VicFlex™ Style AB4 Sprinkler Fitting for Hat Furring Channel Ceiling Systems

⚠ WARNING



- Read and understand all instructions before attempting to install any Victaulic® VicFlex™ products.
- Wear safety glasses, hardhat, and foot protection.
- These installation instructions are intended for an experienced, trained installer.
- The installer shall understand the use of this product and why it was specified for the particular application.
- The installer shall understand common industry safety standards and potential consequences of improper product installation.
- It is the system designer's responsibility to verify suitability of stainless steel flexible hose for use with the intended fluid media within the piping system and external environment.
- The material specifier shall evaluate the effect of chemical composition, pH level, operating temperature, chloride level, oxygen level, and flow rate on stainless steel components to confirm system life will be acceptable for the intended service.

Failure to follow these instructions could cause improper sprinkler operation and product failure, resulting in death or serious personal injury and property damage.

Flexible Hose Listing and Approval Information

Flexible Hose	UL LISTED	FM APPROVED	VdS 6412024	LPCB 104I
AH1	With AB4	With AB4	With AB4	With AB4
AH1-CC	With AB4	With AB4	With AB4	With AB4
AH2	With AB4	With AB4	With AB4	With AB4
AH2-CC	With AB4	With AB4	With AB4	With AB4
AH2-300	-	With AB4	-	-
AH2-638	-	With AB4	-	-
AH4*	-	With AB4	-	-

* SERIES AH4 – REGIONAL AVAILABILITY ONLY

NOTES: Victaulic® VicFlex™ flexible hoses are City of Los Angeles (RR5659) Approved, accepted for use by the City of New York Department of Buildings (MEA 60-05-E), and have the OSHPD Pre-Approval (OPA-2255-07). Flexible hoses are available in lengths from 31 - 72 inches/787 - 1829 mm with either ½-inch/DN15 or ¾-inch/DN20 NPT or BSPT threaded outlets.

Maximum Working Pressure Rating of Flexible Hose:

- 200 psi/14 Bar/1379 kPa (FM)
- 175 psi/12 Bar/1207 kPa (UL)
- 16 Bar/1600 kPa/232 psi (VdS and LPCB)
- 300 psi/21 Bar/2068 kPa (FM – Series AH2-300)

Maximum Ambient Temperature Rating of Flexible Hose:

225° F/107° C

Connection to Sprinkler Piping:

- 1 inch/DN25 NPT/BSPT (UL, FM)
- 1 inch/DN25 IGS (UL, FM, VdS)
- DN20/¾ inch BSPT (VdS)
- DN32/1 ¼ inch BSPT (LPCB)

Minimum Bend Radius of Flexible Hose:

- 3 inch/76 mm (UL – Series AH1, AH1-CC)
- 2 inch/50 mm (UL – Series AH2, AH2-CC)
- 7 inch/178 mm (FM – Series AH1, AH1-CC, AH2, AH2-CC, AH2-638)
- 76 mm/3 inch (VdS – Series AH1, AH1-CC, AH2, AH2-CC)
- 76 mm/3 inch (LPCB – Series AH1, AH2)
- 8 inch/203 mm (FM – Series AH2-300)

Maximum K-Factor of Sprinkler to be Connected to Sprinkler Reducing Nipple:

Refer to footnotes in the “Friction Loss Data” section

Maximum Number of 90° Bends Per Flexible Hose:

Refer to the “Friction Loss Data” section

Flexible Hose Bend Characteristics:

NOTE: For out-of-plane (three-dimensional) bends, care shall be taken to avoid imparting torque on the flexible hose.

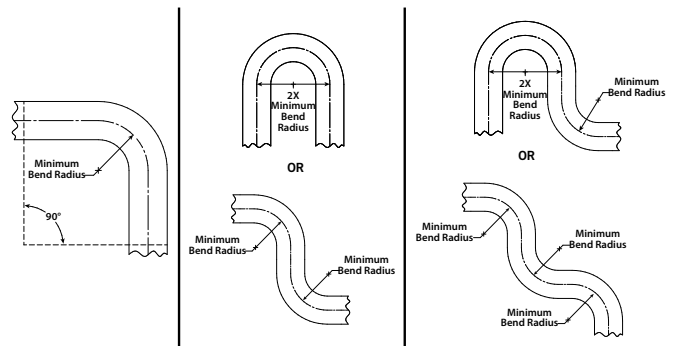

SCAN QR CODE FOR ACCESS TO THE FULL I-VICFLEX.BRG BEND RADIUS GUIDE INSTRUCTIONS ON VICTAULIC.COM

INTRODUCTION

Victaulic® VicFlex™ Sprinkler Fittings connect the sprinkler piping directly to the sprinkler using a flexible hose and fittings and are designed for use in hat furring channel ceiling applications. Each drop assembly comes with one flexible hose, one adapter nipple or captured coupling, one sprinkler reducing nipple, and the Style AB4 Bracket.

IMPORTANT INSTALLATION INFORMATION

- Victaulic® VicFlex™ products shall be installed according to current, applicable National Fire Protection Association (NFPA 13, 13D, 13R, etc.) standards or equivalent standards and in accordance with applicable building and fire codes. Victaulic® VicFlex™ products are intended to be installed in wet, dry, or preaction actuated systems. Deviations from these standards or alterations to Victaulic® VicFlex™ products or sprinklers will void any Victaulic warranty and will impact system integrity. Installations shall meet the provisions of the local authority having jurisdiction and local codes, as applicable, and shall comply with all design specifications.
- Drop ceiling construction shall meet the requirements of ASTM C645 and shall be installed in accordance with ASTM C754.
- Victaulic® VicFlex™ Sprinkler Fittings and Style AB4 Brackets shall not be intermixed with other manufacturer's flexible sprinkler products.
- **When using recessed sprinklers, the standard long elbow reducer is recommended.**
- **Refer to the specific Victaulic product submittal for applications and listing information. In addition, when installing Victaulic FireLock® Automatic Sprinklers with Victaulic® VicFlex™ Sprinkler Fittings, refer to the I-40 Installation and Maintenance Instructions for details on sprinkler installation requirements. Submittals and installation instructions can be downloaded at victaulic.com.**
- Size the piping system to provide at least the minimum required flow rate for the sprinkler system.
- Per NFPA requirements, flush the system to remove foreign material. Continue to flush the system until water runs clear.
- **DO NOT** install sprinkler system piping through heating ducts.
- **DO NOT** connect sprinkler system piping to domestic hot water systems.
- **DO NOT** allow electrical wiring or other cabling to be hung or wrapped around the sprinkler piping system.
- **DO NOT** install sprinklers and sprinkler fittings where they will be exposed to temperatures that exceed the maximum ambient temperature rating for the sprinkler and sprinkler fittings.
- The flexible hose shall not be bent or fluctuated up-and-down or side-to-side when it is pressurized.
- **Flexible hose and fittings have limited flexibility* and are intended only to be installed with bends not less than their respective minimum bend radii. DO NOT install flexible hose in a straight configuration.**
- Protect wet piping systems from freezing temperatures.
- If construction is altered, the building owner or their representative is responsible for referencing applicable standards to determine if additional sprinklers or other system adjustments are required.
- The building owner or their representative is responsible for maintaining the fire protection system in proper operating condition.
- For minimum maintenance and inspection requirements, refer to NFPA 25 and any other applicable NFPA standards that describe the care and maintenance of sprinkler systems. In addition, the authority having jurisdiction may have additional maintenance, testing, and inspection requirements that shall be followed.

WARNING

- **Relocation of Victaulic® VicFlex™ products SHALL be performed by qualified personnel familiar with the system's original design criteria, sprinkler listings/approvals, and state and local codes (including NFPA 13 standards).**

Failure to relocate this Victaulic® VicFlex™ product properly could affect its performance during a fire, resulting in death or serious personal injury and property damage.

* Reference UL 2443: Section 25.1

FLEXIBLE HOSE ASSEMBLY DRAWINGS

Refer to pages 11 – 15 of this manual for flexible hose technical data.

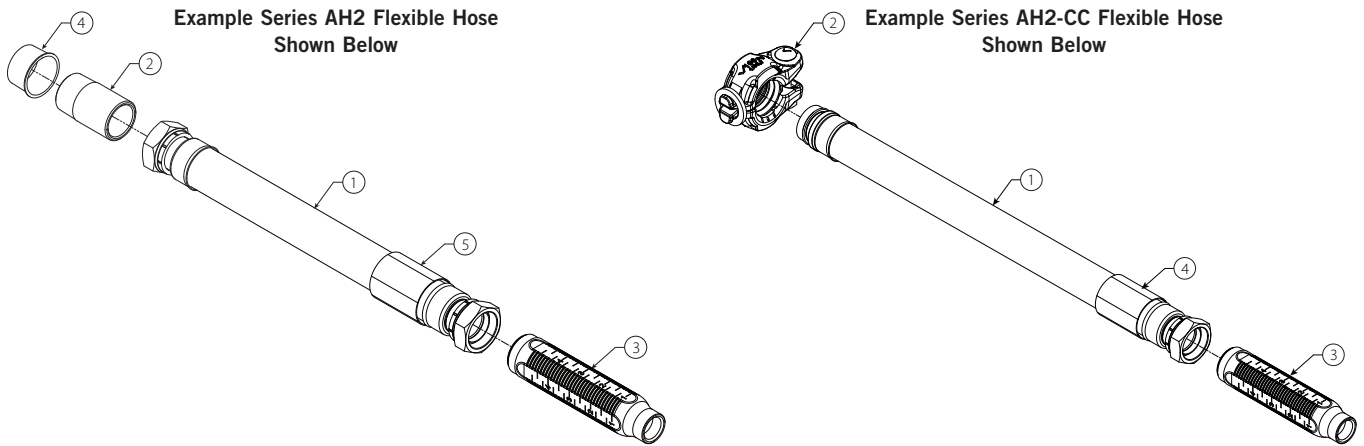

Item	Example Series AH2 Description	Example Series AH2-CC Description
1	Flexible Hose Assembly	Flexible Hose Assembly
2	Adapter Nipple	Coupling Assembly
3	Reducer (Flexible Hose to Sprinkler)	Reducer (Flexible Hose to Sprinkler)
4	Shipping Cap	Identification Sleeve
5	Identification Sleeve	-

STYLE AB4 BRACKET ASSEMBLY DRAWING

Refer to pages 8 – 9 of this manual for bracket installation instructions.

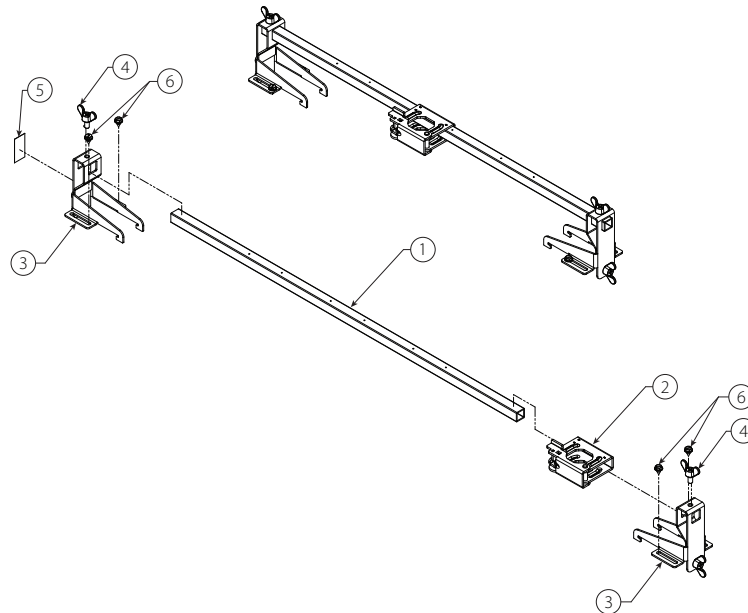

Item	Description
1	24-inch/610-mm or 48-inch/1219-mm Square Bar*
2	Center Gate Assembly with Adjustment Screw
3	Style AB4 End Bracket with Wing Screw
4	Wing Screw
5	Relocation Warning Label
6	Sheet Metal Screw (#10 - 24 x 3/8 inch)

* Reference submittal document 10.85 for listing information. Square bar length is in reference to nominal ceiling grid spacing.

1-INCH/DN25 IGS CONNECTION TO THE SPRINKLER PIPING USING A SERIES AH1-CC OR SERIES AH2-CC FLEXIBLE HOSE

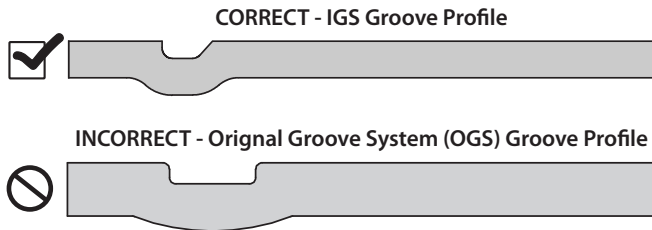

Pipe and grooves are not shown to scale

The Style 108 Coupling of the Series AH1-CC and AH2-CC shall be used **ONLY** with sprinkler piping connections that are prepared to Victaulic IGS proprietary groove specifications. **DO NOT** attempt to install the coupling on sprinkler piping connections that are prepared to any other groove specification. Refer to Victaulic publication 25.14 for the IGS groove specification, which can be downloaded at victaulic.com.

WARNING

- The flexible hose shall not be bent or fluctuated up-and-down or side-to-side when it is pressurized for test.
- Failure to follow this instruction could cause improper sprinkler operation, resulting in death or serious personal injury and property damage.

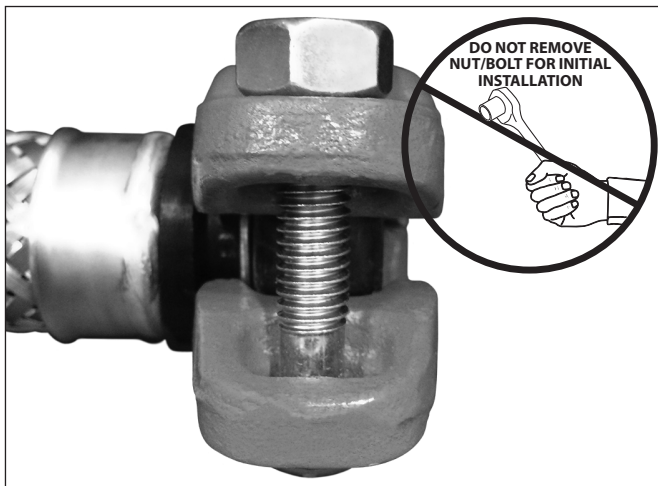

- DO NOT DISASSEMBLE THE COUPLING:** The Style 108 Coupling of the Series AH1-CC and AH2-CC is designed so that the installer does not need to remove the bolt, nut, and linkage for installation. This facilitates installation by allowing the installer to directly insert the sprinkler piping's grooved end into the coupling.
- The outside surface of the sprinkler piping, between the groove and the end of the sprinkler piping, shall be smooth and free from indentations, projections, weld seam anomalies, and roll marks to ensure a leak-tight seal. All oil, grease, loose paint, dirt, and cutting particles shall be removed.

The sprinkler piping's outside diameter ("OD"), groove dimensions, and maximum allowable flare diameter shall be within the tolerances published in current Victaulic IGS specifications, publication 25.14, which can be downloaded at victaulic.com.

- Check the gasket to verify that it is suitable for the intended service. The color code identifies the material grade. Refer to Victaulic publication 05.01 for the color code chart, which can be downloaded at victaulic.com. **REFER TO THE NOTICE BELOW FOR IMPORTANT GASKET INFORMATION.**
- 3a. IF ANY CONDITIONS LISTED IN THE NOTICE ARE MET, APPLY A THIN COAT OF A COMPATIBLE LUBRICANT, SUCH AS VICTAULIC LUBRICANT OR SILICONE LUBRICANT, ONLY TO THE GASKET SEALING LIPS.

CAUTION

- If any conditions listed in the notice are met, a thin coat of a compatible lubricant shall be applied only to the gasket sealing lips to prevent pinching, rolling, or tearing during assembly.
- Failure to use a compatible lubricant will cause gasket damage, resulting in joint leakage and property damage.

NOTICE

- Series AH1-CC and AH2-CC Flexible Hoses are designed for use **ONLY** in wet, dry, and preaction actuated fire protection systems (temperatures greater than -40°F/-40°C).
- Gaskets for Style 108 Coupling assemblies of Series AH1-CC and AH2-CC Flexible Hoses are provided with *Vic-Plus*. Additional lubrication is not required for the initial installation of wet pipe systems that are installed at or continuously operating above 0°F/-18°C. Refer to Victaulic publication 05.03 for the *Vic-Plus* Safety Data Sheet (SDS), which can be downloaded at victaulic.com.

Supplemental lubrication is required only if any of the following conditions exist. Apply a thin coat of a compatible lubricant to the gasket sealing lips, as noted in step 3a on this page. It is not necessary to remove the gasket from the housings to apply additional lubricant to the exterior surface.

- If the installation or continuous operating temperature is below 0°F/-18°C
- If the gasket has been exposed to fluids prior to installation
- If the surface of the gasket does not have a hazy appearance
- If the gasket is being installed into a dry pipe system
- If the system will be subjected to air tests prior to being filled with water
- If the gasket was involved in a previous installation
- If the gasket sealing surfaces of the pipe contain raised or undercut weld seams, or cracks or voids at the weld seams

Lubricated gaskets will not enhance sealing capabilities on adverse pipe conditions. Pipe condition and pipe preparation shall conform to the requirements listed in these product installation instructions.

WARNING



- Never leave a Style 108 Coupling of a Series AH1-CC or AH2-CC partially assembled. A partially assembled coupling poses a drop or fall hazard during installation and a burst hazard during testing.
 - Keep hands away from the opening of the coupling when attempting to insert the grooved sprinkler piping into the coupling.
- Failure to follow these instructions could result in serious personal injury and property damage.

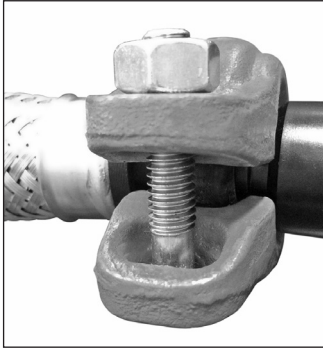

4. Assemble the joint by inserting the grooved end of the sprinkler piping into the opening of the coupling. The grooved sprinkler piping shall be inserted into the coupling until contact with the center leg of the gasket occurs. A visual check is required to verify that the coupling keys align with the groove in the sprinkler piping and engage with the spacer on the inlet end of the flexible hose.

WARNING

- The nut shall be tightened until metal-to-metal contact occurs at the bolt pads.
- Failure to follow instructions for tightening hardware could result in:
- Personal injury or death
 - Bolt damage or fracture
 - Damaged or broken bolt pads or fractures to housings
 - Joint leakage and property damage

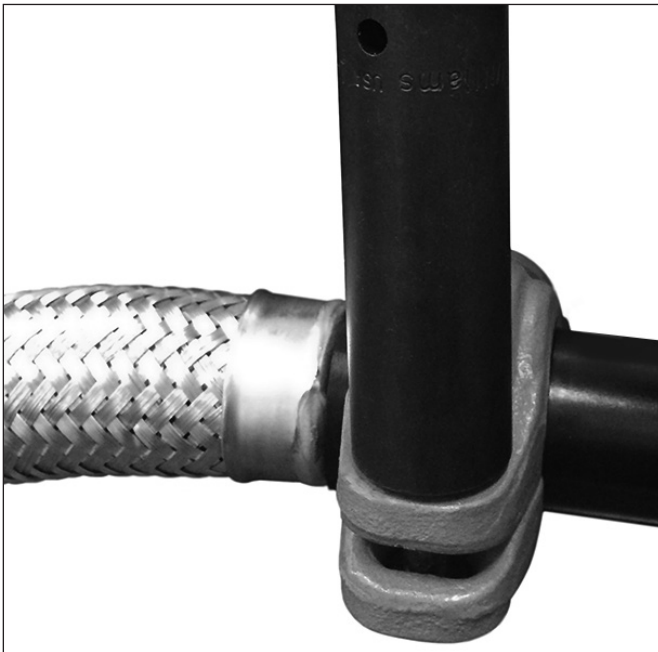

WARNING

- Visual inspection of each joint is required.
 - Improperly assembled joints shall be corrected before the system is tested or placed into service.
 - Any components that exhibit physical damage due to improper assembly shall be replaced.
- Failure to follow these instructions could cause joint failure, resulting in death or serious personal injury and property damage.

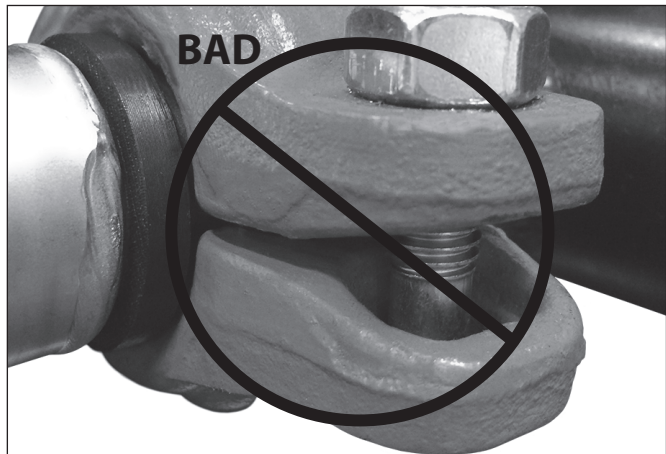
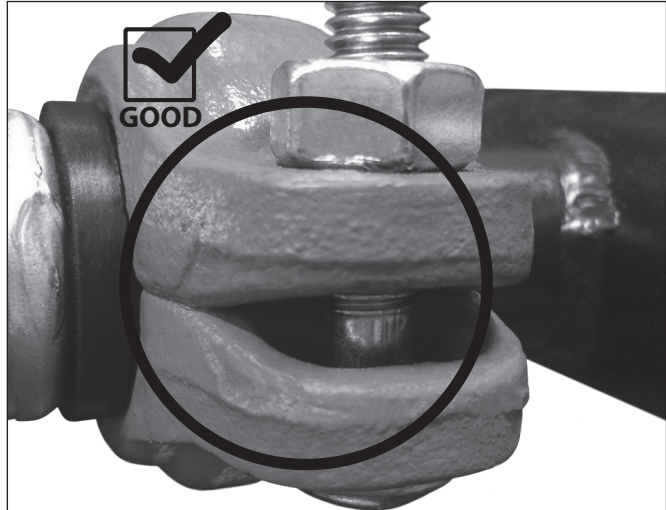

6. Visually inspect the bolt pads at each joint to verify that metal-to-metal contact is achieved in accordance with step 5.

NOTICE

- Refer to the instructions on page 10 for reassembly requirements.



OVAL NECK OF BOLT SEATED PROPERLY



OVAL NECK OF BOLT NOT SEATED PROPERLY

5. Using an impact wrench or standard socket wrench with an 1/16-inch/17-mm deep well socket, tighten the nut until metal-to-metal contact occurs at the bolt pads. Verify that the oval neck of the bolt seats properly in the bolt hole. DO NOT continue to tighten the nut after metal-to-metal bolt pad contact is achieved. **NOTE:** During tightening, support the hose near the Style 108 Coupling to verify that the inlet end of the Series AH1-CC or AH2-CC Flexible Hose remains straight and aligned with the coupling.

INSTRUCTIONS FOR INITIAL USE OF A VICTAULIC® FIRELOCK™ NO. 101 90° ELBOW OR NO. 102 STRAIGHT TEE INSTALLATION-READY™ FITTING WITH A SERIES AH1-CC OR AH2-CC FLEXIBLE HOSE (1-INCH/DN25 IGS CONNECTION)

NOTICE

- The following procedure applies only to 1-inch/DN25 No. 101 90° Elbows and No. 102 Straight Tees (IGS connection).
- No. 101 90° Elbows and No. 102 Straight Tees do not ship preassembled to the Series AH1-CC or AH2-CC Flexible Hose.
- The No. 101 or No. 102 does not need to be fully disassembled for initial installation onto the inlet end of the Series AH1-CC or AH2-CC Flexible Hose.

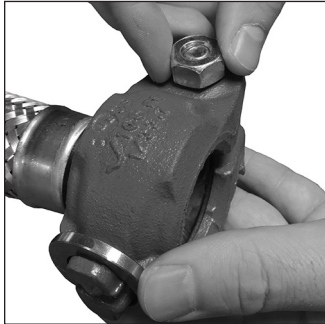

1. Loosen the nut of the Style 108 Coupling. Remove the Style 108 Coupling from the end of the Series AH1-CC or AH2-CC Flexible Hose.

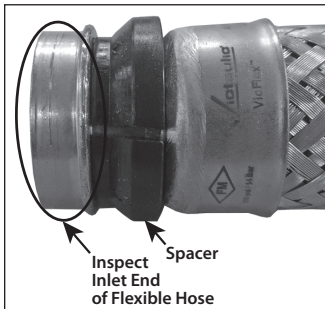

2. Inspect the inlet end of the Series AH1-CC or AH2-CC Flexible Hose to verify that there is no damage (dents, crushed edges, etc.). A new, Victaulic-supplied Series AH1-CC or AH2-CC Flexible Hose shall be used if any damage is present.
3. Verify that the spacer is oriented on the inlet end of the Series AH1-CC or AH2-CC Flexible Hose, as shown to the left.

4. Loosen and remove the hardware from the side of the No. 101 90° Elbow or No. 102 Straight Tee that is intended to connect with the inlet of the Series AH1-CC or AH2-CC Flexible Hose.

NO. 101

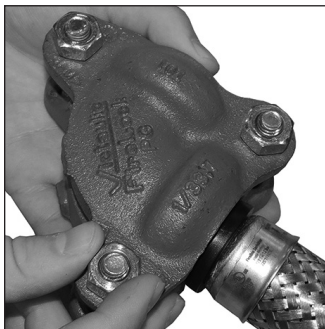

NO. 102

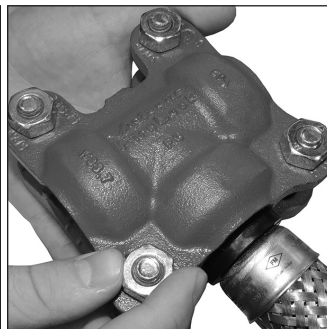

5. Insert the inlet end of the Series AH1-CC or AH2-CC Flexible Hose into the No. 101 90° Elbow or No. 102 Straight Tee. Verify that the gasket is seated fully in the gasket pocket of each housing and that the housings' keys engage with the spacer on the inlet end of the Series AH1-CC or AH2-CC Flexible Hose.
- 5a. Reinstall the two bolts and nuts that were removed in step 4.
NOTE: Verify that the oval neck of each bolt seats properly in the bolt holes. DO NOT tighten the nuts completely. The bolt pads need to be set at a gap for installation of the fitting. The nuts should be flush with the top of each bolt to provide the proper gap. Use caution when handling the fitting/hose assembly (the fitting may not be secured completely to the inlet end of the Series AH1-CC or AH2-CC Flexible Hose).

6. Follow the steps in the I-101/103 or I-102/104 installation instructions for the required tightening sequence. **NOTE:** During tightening, verify that the inlet end of the Series AH1-CC or AH2-CC Flexible Hose remains straight and aligned with the opening of the No. 101 90° Elbow or No. 102 Straight Tee. The I-101/103 or I-102/104 can be accessed and downloaded by scanning the applicable QR code below. In addition, these instructions contain important reassembly instructions and shall be referenced any time a No. 101 90° Elbow or No. 102 Straight Tee is removed from the sprinkler piping and reused.



SCAN QR CODE FOR ACCESS TO THE FULL I-101/103
INSTALLATION INSTRUCTIONS ON VICTAULIC.COM



SCAN QR CODE FOR ACCESS TO THE FULL I-102/104
INSTALLATION INSTRUCTIONS ON VICTAULIC.COM

CONNECTION TO THE SPRINKLER PIPING USING AN ADAPTER NIPPLE AND A SERIES AH1, AH2, AH2-300, OR AH2-638 FLEXIBLE HOSE

WARNING

- The flexible hose shall not be bent or fluctuated up-and-down or side-to-side when it is pressurized for test.

Failure to follow this instruction could cause improper sprinkler operation, resulting in death or serious personal injury and property damage.

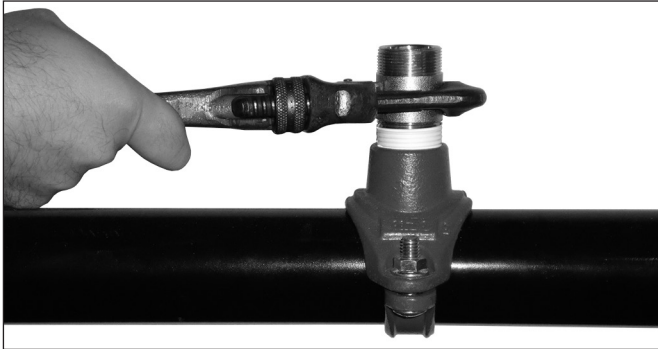

1. Apply pipe joint compound or PTFE thread sealant tape to the tapered threads of the adapter nipple, in accordance with the pipe joint compound or tape manufacturer's instructions. Using a pipe wrench, tighten the adapter nipple into the sprinkler piping.



2. Confirm that the seal inside the nut of the flexible hose is in place and is free from damage prior to installation. Connect the nut to the adapter nipple, as shown above.
 - DO NOT use pipe joint compound or PTFE thread sealant tape on the threads of the adapter nipple. The seal inside the nut of the flexible hose provides the leak-proof connection.
 - Tighten the connection nut to a torque of 40ft-lbs/54 N•m (approximately ½ to ¾ of a turn past hand-tight). **NOTE:** To prevent damage to the seal, tighten the assembly by applying torque only to the connection nut and DO NOT exceed the specified torque.

INSTALLATION OF THE SPRINKLER REDUCING NIPPLE ONTO THE FLEXIBLE HOSE

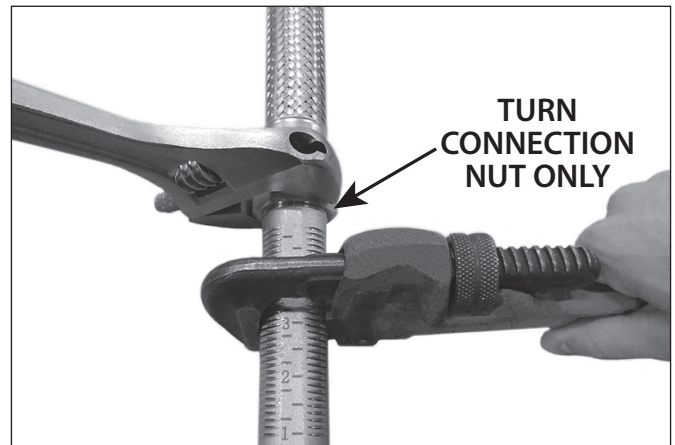

1. Confirm that the seal inside the nut of the flexible hose is in place and is free from damage prior to installation. Connect the nut to the sprinkler reducing nipple. **SHORT 90° ELBOW REDUCERS ARE TYPICALLY USED WITH CONCEALED SPRINKLERS.**
 - DO NOT use pipe joint compound or PTFE thread sealant tape on the fine threads of the sprinkler reducing nipple. The seal inside the nut of the flexible hose provides the leak-proof connection.
 - Tighten the connection nut to a torque of 40ft-lbs/54 N•m (approximately ½ to ¾ of a turn past hand-tight). **NOTE:** To prevent damage to the seal, tighten the assembly by applying torque only to the connection nut and DO NOT exceed the specified torque.

INSTALLATION FOR ASTM C645 HAT FURRING CHANNEL CEILING SYSTEMS INSTALLED IN ACCORDANCE WITH ASTM C754 STANDARDS

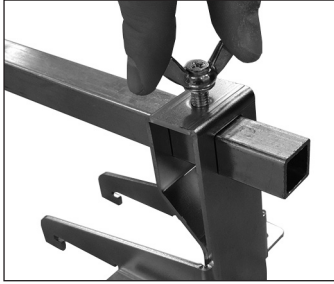

1. Loosen the wing screw on top of each end bracket assembly to allow the end brackets to slide on the square bar.

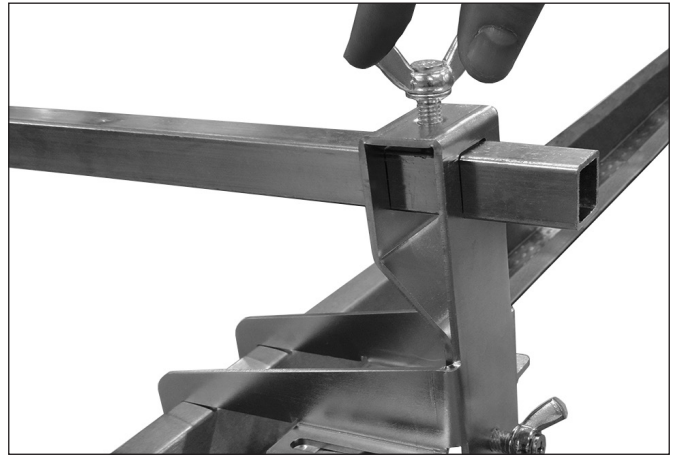

4. Tighten the wing screw on top of each end bracket assembly to a torque of 36 inch-lbs/4 N•m (approximately ½ to ¾ of a turn past hand-tight) to secure the end brackets to the square bar.

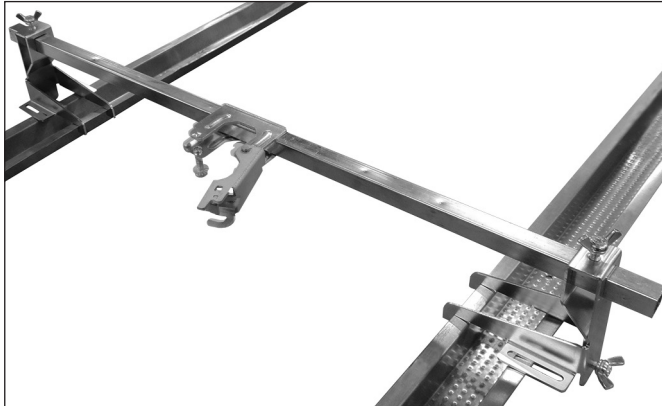

2. Attach the end brackets to the ASTM C645 hat furring channel ceiling system installed in accordance with ASTM C754 standards. Verify that the end brackets engage the hat furring channels, as shown above. Adjust the Style AB4 Bracket assembly to the appropriate location on the hat furring channel.

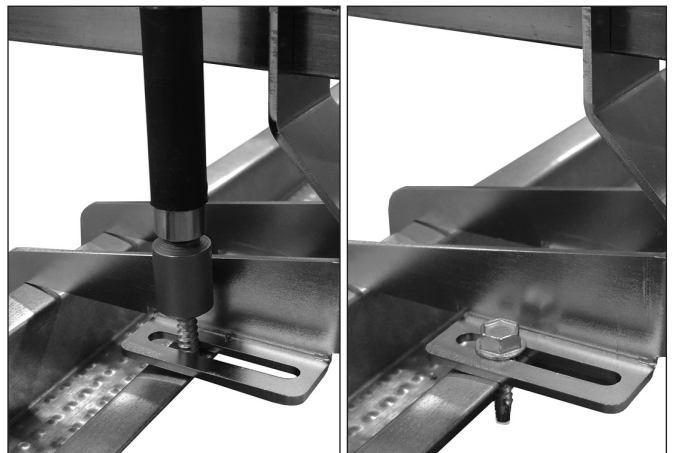

5. Using a 5/16-inch hex drive bit, tighten the #10-24 x 3/8-inch sheet metal screw (provided with the bracket) through the two locations on each end bracket and into the hat furring channels.

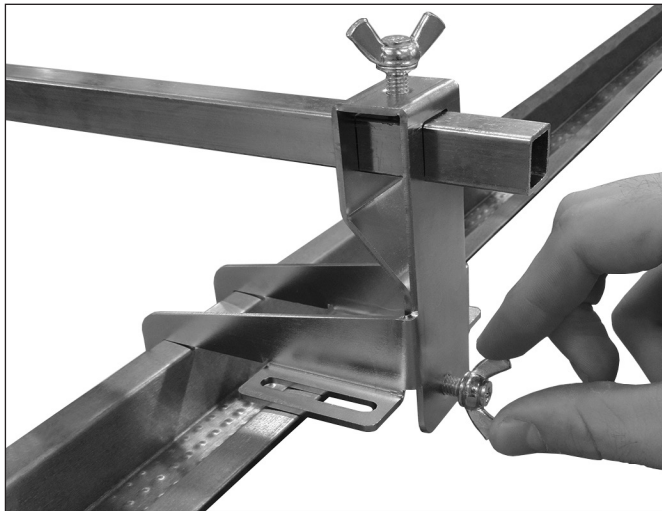

3. Hand-tighten the wing screw on the side of each end bracket until the end bracket is secured to the hat furring channels.

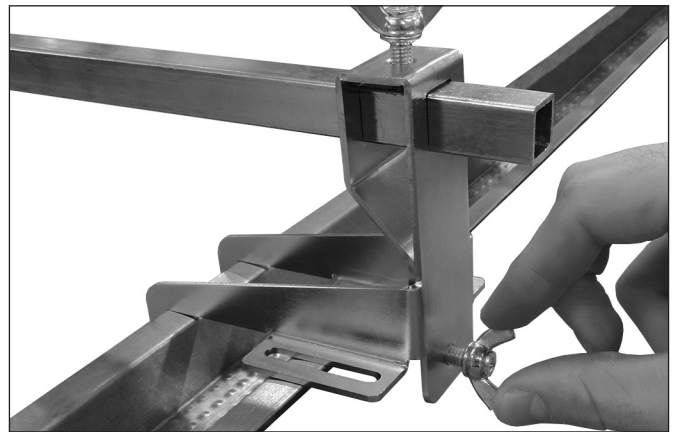

6. Verify that the wing screw on the side of each end bracket is hand-tightened until the end bracket is secured to the hat furring channels.

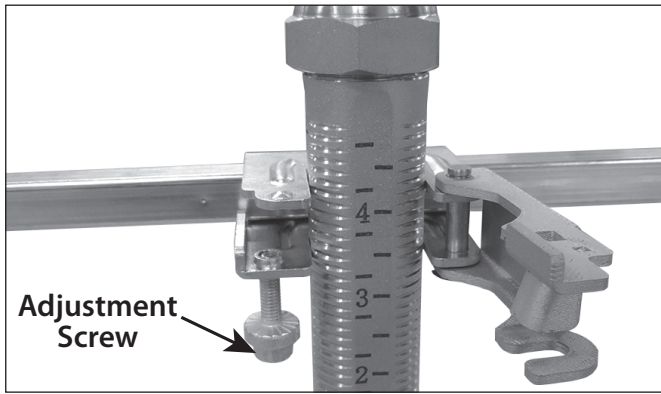

7. Move the center gate assembly of the Style AB4 Bracket to the desired location. Using a #2 square recessed drive bit, loosen the adjustment screw, then push open the center gate assembly. Slide the sprinkler reducing nipple into the center gate assembly. **NOTE:** The adjustment screw of the center gate assembly is staked to resist removal.

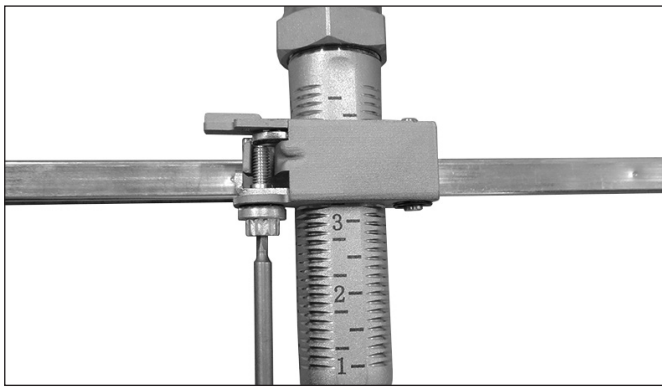

- 7a. Close the gate around the sprinkler reducing nipple. The gate will snap together tightly around the sprinkler reducing nipple. Using a #2 square recessed drive bit, tighten the adjustment screw to a torque of 75 inch-lbs/8.5 N•m (until adjustment screw makes metal-to-metal contact with bottom of gate). **NOTE:** The sprinkler reducing nipple can be adjusted after the drywall is installed by using the adjustment screw on the center gate assembly.

SPRINKLER INSTALLATION:

Install the sprinkler by following the manufacturer's installation instructions. For Victaulic sprinklers, refer to the I-40 Victaulic® FireLock™ Automatic Sprinklers Installation and Maintenance Instructions.

INSTRUCTIONS FOR REASSEMBLY OF A SERIES AH1-CC OR SERIES AH2-CC FLEXIBLE HOSE

WARNING

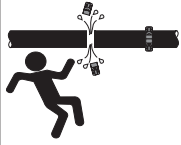

- Always depressurize and drain the piping system before attempting to install, remove, adjust, or maintain any Victaulic piping products.

Failure to follow this instruction could result in death or serious personal injury and property damage.

- Verify that the system is depressurized and drained completely before attempting to remove a Series AH1-CC or AH2-CC Flexible Hose from the sprinkler piping.
- While supporting the Style 108 Coupling, loosen the nut until backed off no further than flush with the end of the bolt. Carefully remove the flexible hose/coupling assembly from the sprinkler piping.
- Fully disassemble the Style 108 Coupling from the inlet end of the Series AH1-CC or AH2-CC Flexible Hose.
- Inspect the gasket of the Style 108 Coupling for any damage or wear (tears in gasket lips, deformities in gasket lips, or pinched sections at the bolt pad locations). A new, Victaulic-supplied Style 108 Coupling shall be used if any gasket damage is present.
- Verify that the outside surface of the sprinkler piping, between the groove and the end of the sprinkler piping, is smooth and free from indentations, projections, weld seam anomalies, and roll marks to ensure a leak-tight seal. All oil, grease, loose paint, dirt, and cutting particles shall be removed.

The sprinkler piping's outside diameter ("OD"), groove dimensions, and maximum allowable flare diameter shall be within the tolerances published in current Victaulic IGS specifications, publication 25.14, which can be downloaded at victaulic.com.

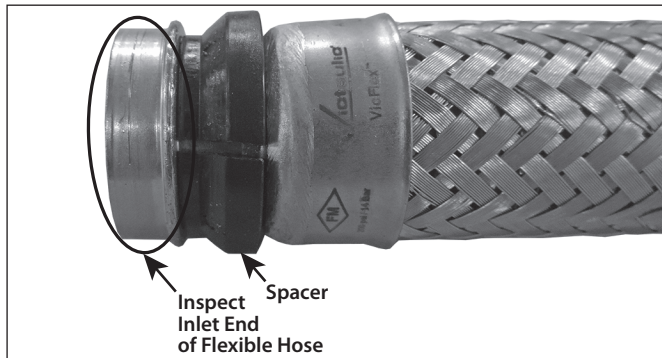

- Inspect the end of the Series AH1-CC or AH2-CC Flexible Hose to verify that there is no damage (dents, crushed edges, etc.). A new, Victaulic-supplied Series AH1-CC or AH2-CC Flexible Hose shall be used if any damage is present.
- Verify that the spacer is oriented on the inlet end of the Series AH1-CC or AH2-CC Flexible Hose, as shown above.

CAUTION

- A thin coat of a compatible lubricant shall be used to prevent the gasket from pinching, rolling, or tearing during reassembly. Failure to use a compatible lubricant will cause gasket damage, resulting in joint leakage and property damage.



- Apply a thin coat of a compatible lubricant, such as Victaulic Lubricant or silicone lubricant, to the gasket's sealing lips and exterior, as shown above. For gaskets that are being reused, it is normal for the gasket to have a hazy white appearance after it has been in service.



- Place the lubricated gasket onto the inlet end of the flexible hose, then place the Style 108 Coupling housings over the gasket. Verify that the gasket is seated fully in the gasket pocket of each housing and that the housings' keys engage with the spacer.



- Install the linkage onto the housings, as shown to the left.



- Install the bolt, and thread a nut onto the bolt. **NOTE:** Verify that the oval neck of the bolt seats properly in the bolt hole. DO NOT tighten the nut completely. The bolt pads need to be set at a gap for reinstallation of the coupling. The nut should be flush with the top of the bolt to provide the proper gap.

- Follow all steps on page 5.

TECHNICAL DATA FOR FLEXIBLE HOSES

The following section provides friction loss information for flexible hoses that can be used with Style AB4 Brackets.

WARNING

- It is the system designer's responsibility to verify suitability of stainless steel flexible hose for use with the intended fluid media within the piping system and external environment.
- The material specifier shall evaluate the effect of chemical composition, pH level, operating temperature, chloride level, oxygen level, and flow rate on stainless steel components to confirm system life will be acceptable for the intended service.

Failure to follow these instructions could cause product failure, resulting in death or serious personal injury and property damage.

SERIES AH1 AND AH1-CC FLEXIBLE HOSE FRICTION LOSS DATA (FM AND UL)

Model	Length of Flexible Hose inches/mm	Outlet Size# inches/Metric	Equivalent Length of 1-inch/DN25 Schedule 40 Pipe feet/meters		Maximum Number of 90° Bends§	
			FM*	UL‡	FM	UL
AH1-31 AH1-CC-31	31 790	½ DN15	53.8 16.4	52.0 15.9	2	3
		¾ DN20	44.3 13.5	55.0 16.8		
AH1-36 AH1-CC-36	36 915	½ DN15	63.7 19.4	63.0 19.2	2	4
		¾ DN20	55.5 16.9	66.0 20.1		
AH1-48 AH1-CC-48	48 1220	½ DN15	87.9 26.8	78.0 23.8	3	4
		¾ DN20	83.0 25.3	80.0 24.4		
AH1-60 AH1-CC-60	60 1525	½ DN15	112.2 34.1	88.0 26.8	4	4
		¾ DN20	110.4 33.6	90.0 27.4		
AH1-72 AH1-CC-72	72 1830	½ DN15	136.5 41.6	112.0 34.1	4	5
		¾ DN20	137.9 42.0	118.0 36.0		

* 7-inch/178-mm minimum bend radius (tested with standard 5¾-inch/146-mm length straight reducer)
 ‡ 3-inch/76-mm minimum bend radius (tested and UL Listed only with standard 5¾-inch/146-mm length straight reducer)
 # ¾-inch/DN20 outlet data shown with K14.0 - For other K-factor friction loss data, refer to Victaulic submittal 10.95
 For the UL Listing, when the 48-inch/1220-mm length bracket is used with the Series AH1 or AH1-CC Flexible Hose, the maximum sprinkler K-factor is K8.0 and the maximum spacing is 30 inches/762 mm
 § A higher number of bends may be permitted, provided the sum of degrees is equal to or less than the total maximum allowable degrees of bends (e.g. Two 90° bends equal 180°. Three 90° bends equal 270°). The minimum bend radius and maximum number of 90° offset (bends), stated in these installation instructions, refer to the final installed condition of the hose.
 For friction loss data for elbows, refer to Victaulic submittal 10.95.
NOTE: Differences in equivalent lengths are due to varying test methods, per UL 2443 and FM 1637 standards. Refer to these standards for additional information regarding friction loss test methods.
When using a No. 101 90° Elbow or a No. 102 Straight Tee in place of a Style 108 Coupling on the end of a Series AH1-CC Flexible Hose, the friction loss data shown above shall be added to the No. 101 or No. 102 friction loss data published in Victaulic submittal 10.54.

SERIES AH2 AND AH2-CC FLEXIBLE HOSE FRICTION LOSS DATA (FM AND UL)

Model	Length of Flexible Hose inches/mm	Outlet Size# inches/Metric	Equivalent Length of 1-inch/DN25 Schedule 40 Pipe feet/meters		Maximum Number of 90° Bends§	
			FM*	UL‡	FM	UL
AH2-31 AH2-CC-31	31 790	½ DN15	13.8 4.2	16.0 4.9	2	4
		¾ DN20	14.9 4.5	17.0 5.2		
AH2-36 AH2-CC-36	36 915	½ DN15	16.6 5.1	21.0 6.4	2	5
		¾ DN20	19.4 5.9	23.0 7.0		
AH2-48 AH2-CC-48	48 1220	½ DN15	23.4 7.1	32.0 9.8	3	8
		¾ DN20	30.3 9.2	37.0 11.3		
AH2-60 AH2-CC-60	60 1525	½ DN15	30.2 9.2	46.0 14.0	4	10
		¾ DN20	33.9 10.3	46.0 14.0		
AH2-72 AH2-CC-72	72 1830	½ DN15	37.0 11.3	55.0 16.8	4	12
		¾ DN20	37.5 11.4	53.0 16.2		

* 7-inch/178-mm minimum bend radius (tested with standard 5¾-inch/146-mm length straight reducer)
 ‡ 2-inch/50-mm minimum bend radius (tested and UL Listed only with standard 5¾-inch/146-mm length straight reducer)
 # ¾-inch/DN20 outlet data shown with K14.0 - For other K-factor friction loss data, refer to Victaulic submittal 10.85
 For the UL Listing, when the 48-inch/1220-mm length bracket is used with the Series AH2 or AH2-CC Flexible Hose, the maximum sprinkler K-factor is K8.0 and the maximum spacing is 30 inches/762 mm
 § A higher number of bends may be permitted, provided the sum of degrees is equal to or less than the total maximum allowable degrees of bends (e.g. Two 90° bends equal 180°. Three 90° bends equal 270°). The minimum bend radius and maximum number of 90° offset (bends), stated in these installation instructions, refer to the final installed condition of the hose.
 For friction loss data for elbows, refer to Victaulic submittal 10.85.
NOTE: Differences in equivalent lengths are due to varying test methods, per UL 2443 and FM 1637 standards. Refer to these standards for additional information regarding friction loss test methods.
When using a No. 101 90° Elbow or a No. 102 Straight Tee in place of a Style 108 Coupling on the end of a Series AH2-CC Flexible Hose, the friction loss data shown above shall be added to the No. 101 or No. 102 friction loss data published in Victaulic submittal 10.54.



SERIES AH2-300 FLEXIBLE HOSE FRICTION LOSS DATA (FM)

Model	Length of Flexible Hose inches/mm	Outlet Size# inches/Metric	Equivalent Length of 1-inch/DN25 Schedule 40 Pipe feet/meters*	Maximum Number of 90° Bends§
AH2-300-31	31 790	½ DN15	23.5 7.2	2
		¾ DN20	14.9 4.5	
AH2-300-36	36 915	½ DN15	27.8 8.5	2
		¾ DN20	19.4 5.9	
AH2-300-48	48 1220	½ DN15	38.2 11.6	3
		¾ DN20	30.3 9.2	
AH2-300-60	60 1525	½ DN15	42.4 12.9	4
		¾ DN20	33.9 10.3	
AH2-300-72	72 1830	½ DN15	46.6 14.2	4
		¾ DN20	37.5 11.4	

* 8-inch/203-mm minimum bend radius (tested with standard 5 ¾-inch/146-mm length straight reducer)
 # ¾-inch outlet data shown with K14.0 - For other K-factor friction loss data, refer to Victaulic submittal 10.84
 § A higher number of bends may be permitted, provided the sum of degrees is equal to or less than the total maximum allowable degrees of bends (e.g. Two 90° bends equal 180°. Three 90° bends equal 270°). The minimum bend radius and maximum number of 90° offset (bends), stated in these installation instructions, refer to the final installed condition of the hose.
 For friction loss data for elbows, refer to Victaulic submittal 10.84.
 NOTE: Differences in equivalent lengths are due to varying test methods, per the FM 1637 standard. Refer to this standard for additional information regarding friction loss test methods.

SERIES AH2-638 FLEXIBLE HOSE FRICTION LOSS DATA (FM)

Model	Length of Flexible Hose inches/mm	Outlet Size# inches/Metric	Equivalent Length of 1-inch/DN25 Schedule 40 Pipe feet/meters*	Maximum Number of 90° Bends
AH2-638	28 711	½ DN15	22.2 6.8	1
		¾ DN20	13.1 3.9	

* 7-inch/178-mm minimum bend radius (tested with standard 5 ¾-inch/146-mm length straight reducer)
 # ¾-inch outlet data shown with K14.0 - For other K-factor friction loss data, refer to Victaulic submittal 10.85
 For friction loss data for elbows, refer to Victaulic submittal 10.85.
 NOTE: Differences in equivalent lengths are due to varying test methods, per the FM 1637 standard. Refer to this standard for additional information regarding friction loss test methods.

SERIES AH4 FLEXIBLE HOSE FRICTION LOSS DATA (FM) – REGIONAL AVAILABILITY ONLY

Model	Length of Flexible Hose inches/mm	Outlet Size# inches/Metric	Equivalent Length of 1-inch/DN25 Schedule 40 Pipe feet/meters*	Maximum Number of 90° Bends§
AH4-31	31 790	1/2 DN15	20.6 6.3	2
		3/4 DN20	16.3 5.0	
AH4-36	36 915	1/2 DN15	29.7 9.0	2
		3/4 DN20	21.8 6.7	
AH4-48	48 1220	1/2 DN15	27.5 8.3	3
		3/4 DN20	28.3 8.6	
AH4-60	60 1525	1/2 DN15	35.7 10.9	4
		3/4 DN20	34.9 10.6	
AH4-72	72 1830	1/2 DN15	45.9 14.0	4
		3/4 DN20	41.5 12.6	

* 7-inch/178-mm minimum bend radius (tested with standard 5 3/4-inch/146-mm length straight reducer)

3/4-inch/DN20 outlet data shown with K14.0 - For other K-factor friction loss data, refer to Victaulic submittal 10.82

§ A higher number of bends may be permitted, provided the sum of degrees is equal to or less than the total maximum allowable degrees of bends

(e.g. Two 90° bends equal 180°. Three 90° bends equal 270°). The minimum bend radius and maximum number of 90° offset (bends), stated in these installation instructions, refer to the final installed condition of the hose.

For friction loss data for elbows, refer to Victaulic submittal 10.82.

NOTE: Differences in equivalent lengths are due to varying test methods, per the FM 1637 standard. Refer to this standard for additional information regarding friction loss test methods.

Series AH4 Flexible Hose Assembly Model Number Correlation

Series AH4 Hose Assembly Designation	Outlet Size	Series AQB Hose Assembly Designation	Series AFB Hose Assembly Designation
AH4-31	1/2	AQB31HLD	AFB31HLD
	3/4	AQB31TLD	AFB31TLD
AH4-36	1/2	AQB36HLD	AFB36HLD
	3/4	AQB36TLD	AFB36TLD
AH4-48	1/2	AQB48HLD	AFB48HLD
	3/4	AQB48TLD	AFB48TLD
AH4-60	1/2	AQB60HLD	AFB60HLD
	3/4	AQB60TLD	AFB60TLD
AH4-72	1/2	AQB72HLD	AFB72HLD
	3/4	AQB72TLD	AFB72TLD

SERIES AH1, AH1-CC, AH2, AND AH2-CC FLEXIBLE HOSE FRICTION LOSS DATA (VDS)

Length of Flexible Hose mm/inches	Outlet Size Metric/inches	Maximum Number of 90° Bends at 76.2-mm/3-inch Bend Radius	Series AH1 and AH1-CC	Series AH2 and AH2-CC
			Equivalent Length of Steel Pipe in meters/feet According to EN 10255 DN 20 (26,9 x 2,65)	Equivalent Length of Steel Pipe in meters/feet According to EN 10255 DN 25 (33,7 x 3,25)
790 31	DN15/½	3	4.0	5.5
	DN20/¾		12.9	18.0
915 36	DN15/½	3	4.6	6.4
	DN20/¾		15.0	21.0
1220 48	DN15/½	3	6.1	8.5
	DN20/¾		20.0	27.9
1525 60	DN15/½	4	7.6	10.7
	DN20/¾		25.0	35.1
1830 72	DN15/½	4	9.2	12.8
	DN20/¾		30.0	42.0

Flexible Hoses are VdS Approved for use in wet systems only.

Only VdS Approved pendent spray sprinklers of 10-mm, 15-mm, and 20-mm nominal diameters with K-factors of 57, 80, and 115 shall be used.

Tested with a 5 ¾-inch/146-mm length straight reducer.

When using a No. 101 90° Elbow or a No. 102 Straight Tee in place of a Style 108 Coupling on the end of a Series AH1-CC or AH2-CC Flexible Hose, the friction loss data shown above shall be added to the No. 101 or No. 102 friction loss data published in Victaulic submittal 10.54.

NOTE: No specific VdS Approval is required for manufacturers of hat furring channel ceiling systems.

SERIES AH1, AH1-CC, AH2, AND AH2-CC FLEXIBLE HOSE FRICTION LOSS DATA (LPCB)

Length of Flexible Hose mm/inches	Outlet Size Metric/inches	Maximum Number of 90° Bends at 76.2-mm/3-inch Bend Radius	Series AH1 and AH1-CC*	Series AH2 and AH2-CC**
			Equivalent Length of Steel Pipe in meters/feet According to EN 10255 DN 25 (33,7 x 3,25)	Equivalent Length of Steel Pipe in meters/feet According to EN 10255 DN 25 (33,7 x 3,25)
790 31	DN15/½	2	13.6	1.8
	DN20/¾		44.6	6.0
915 36	DN15/½	3	16.9	3.6
	DN20/¾		55.4	11.9
1220 48	DN15/½	3	19.9	4.3
	DN20/¾		65.1	14.0
1525 60	DN15/½	3	24.5	4.1
	DN20/¾		80.2	13.6
1830 72	DN15/½	3	28.5	5.5
	DN20/¾		93.4	18.1

* Hose Type 2 and Size: DN20/0.8-inch Nominal ID, per LPS 1261

** Hose Type 2 and Size: DN25/1-inch Nominal ID, per LPS 1261

Series AH1 (104I/01), Series AH2 (104I/02), Series AH1-CC (104I/03), and Series AH2-CC (104I/04) Flexible Hoses are LPCB Approved for use in wet systems only.

Only LPCB Approved pendent spray sprinklers of 10-mm, 15-mm, and 20-mm nominal diameters with K-factors of 57 and 80 shall be used.

Tested with a 5 ¾-inch/146-mm length straight reducer.

When using a No. 101 90° Elbow or a No. 102 Straight Tee in place of a Style 108 Coupling on the end of a Series AH1-CC or AH2-CC Flexible Hose, the friction loss data shown above shall be added to the No. 101 or No. 102 friction loss data published in Victaulic submittal 10.54.

Victaulic® VicFlex™ Style AB4 Sprinkler Fitting for Hat Furring Channel Ceiling Systems

For complete contact information, visit victaulic.com

I-VICFLEX.AB4 7083 REV H UPDATED 10/2018 Z000AB4000

VICTAULIC AND VICFLEX ARE REGISTERED TRADEMARKS OR TRADEMARKS OF VICTAULIC COMPANY AND/OR ITS AFFILIATED ENTITIES
IN THE UNITED STATES AND/OR OTHER COUNTRIES. © 2018 VICTAULIC COMPANY. ALL RIGHTS RESERVED.

