

# MIRO 1200D

**PRODUCT CODE**  
M120D

## LED MIRROR

| SPECIFICATIONS |           |
|----------------|-----------|
| WIDTH          | 1200mm    |
| HEIGHT         | 700mm     |
| DEPTH          | 40mm      |
| WEIGHT         | 19kg      |
| ORIENTATION    | Landscape |

| FEATURES  |
|---|
| Copper Free Mirror                              |
| LED Lighting<br>(Adjustable Colour Temperature) |
| Touch Sensor                                    |
| Demister with 1 Hour Auto Cut-off               |

| LIGHTING SPECIFICATIONS |               |
|-------------------------|---------------|
| CCT                     | 2700K - 6500K |
| CRI                     | >80           |

| INSTALLATION                 |  |
|------------------------------|--|
| Wall mount                   |  |
| Hardwire                     |  |
| Input voltage: 220-240v 50Hz |  |

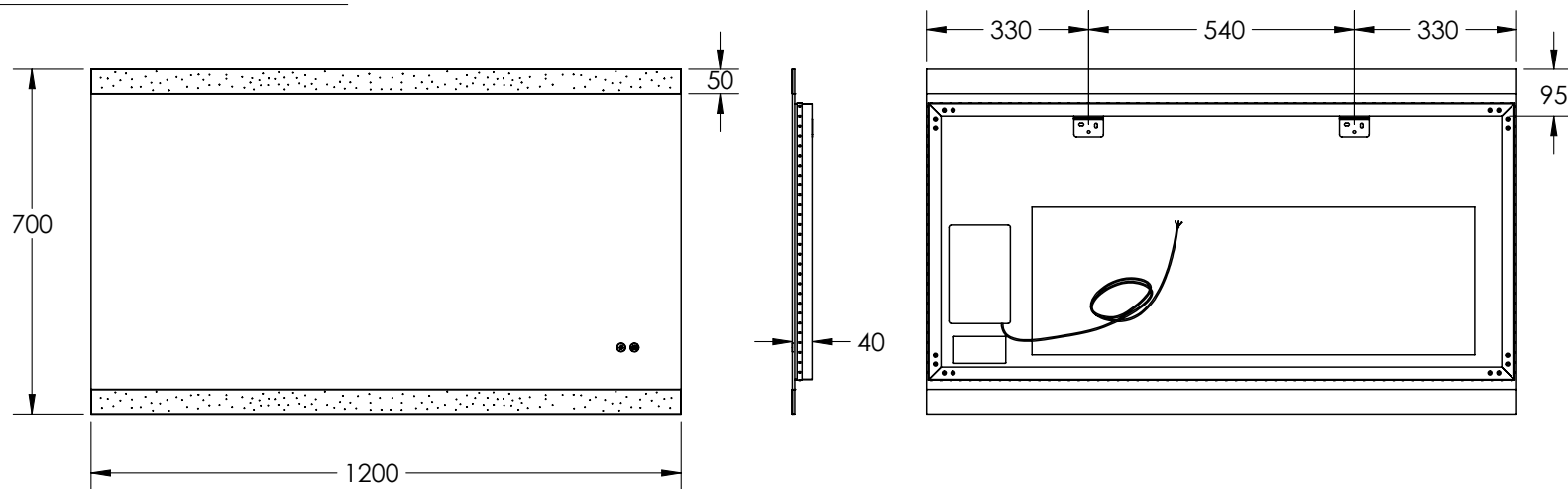

Disclaimer: All LED Products requiring hardwiring must be installed by a licensed electrician in accordance with local regulations. Sizes are in mm and nominal and should be checked prior to installation. Actual colours may vary so please check colour samples before ordering. Installation is acceptance of our products. Installation of faulty, warped, chipped or damaged products will void our warranty.

# MIRO 1200D

**PRODUCT CODE**  
M120D

## LED MIRROR

| SPECIFICATIONS |           |
|----------------|-----------|
| WIDTH          | 1200mm    |
| HEIGHT         | 700mm     |
| DEPTH          | 38mm      |
| WEIGHT         | 19kg      |
| ORIENTATION    | Landscape |

| FEATURES  |  |
|---|--|
| Copper Free Mirror                              |  |
| LED Lighting<br>(Adjustable Colour Temperature) |  |
| Touch Sensor                                    |  |
| Demister with 1 Hour Auto Cut-off               |  |

| LIGHTING SPECIFICATIONS |               |
|-------------------------|---------------|
| CCT                     | 2700K - 6500K |
| CRI                     | >80           |

| INSTALLATION                 |  |
|------------------------------|--|
| Wall mount                   |  |
| Hardwire / Plug              |  |
| Input voltage: 220-240v 50Hz |  |

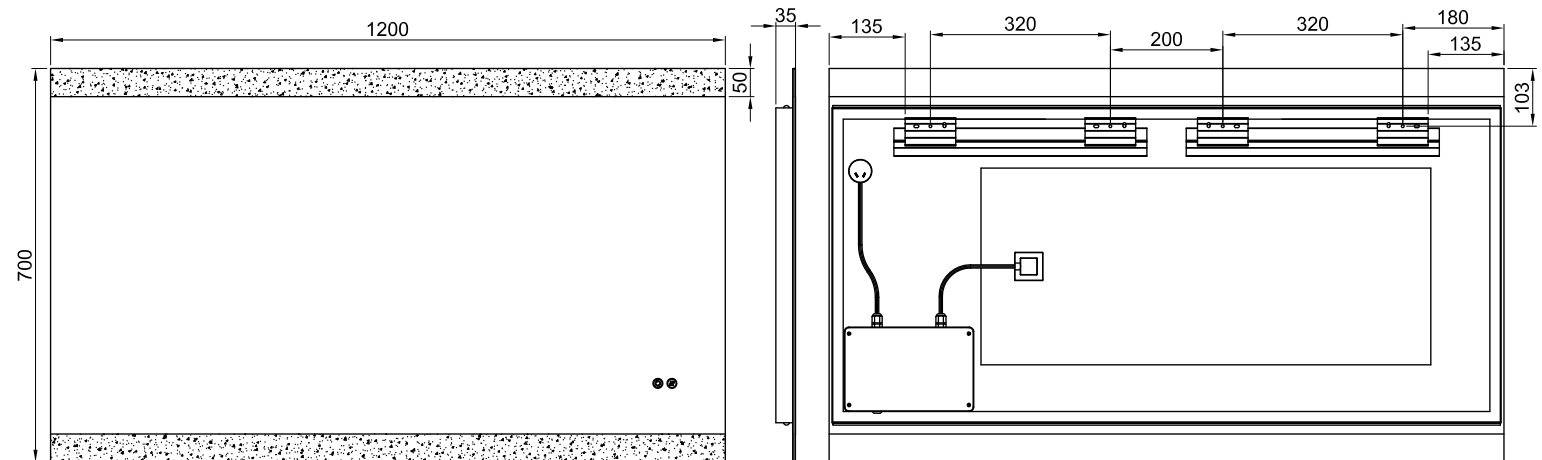

Disclaimer: All LED Products requiring hardwiring must be installed by a licensed electrician in accordance with local regulations. Sizes are in mm and nominal and should be checked prior to installation. Actual colours may vary so please check colour samples before ordering. Installation is acceptance of our products. Installation of faulty, warped, chipped or damaged products will void our warranty.