

NOTE

Before drilling through the bench surface, check that there is a clear area directly underneath for the sprayer hose to retract. Allow 750mm for normal operation.

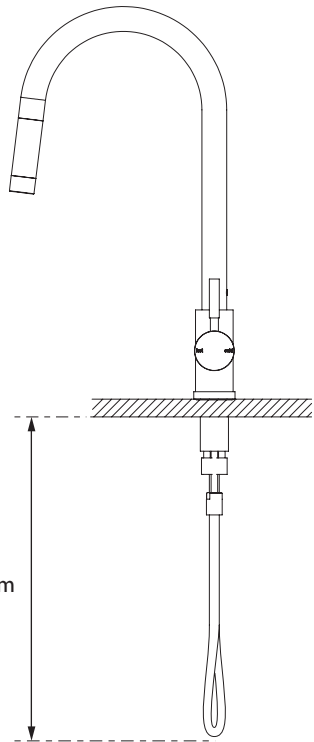

1

For bench mounted installations, use a 35mm hole saw, to cut a neat hole through the bench top.

Remove the Lock Nut, Spacer, and the Sprayer Hose from the mixer Hose Outlet. Feed the Sprayer Hose through the hole and then position the mixer over the hole.

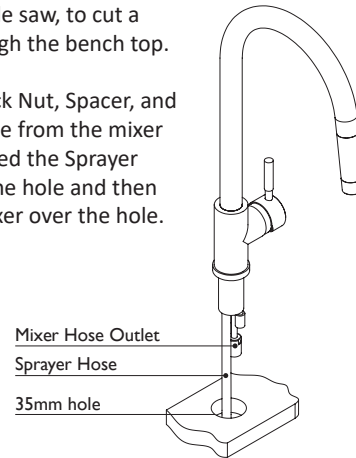

2

Slide the plastic Spacer, Rubber Washer, Metal Washer and Lock Nut over the Sprayer Hose and then over the mixer threaded tail. Tighten the lock nut firmly against the spacer and washers.

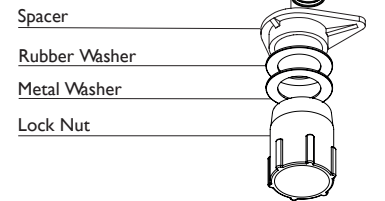

3

Screw the sprayer hose fitting into the mixer hose outlet. Then insert the sprayer hose into the fitting until it clicks into place.

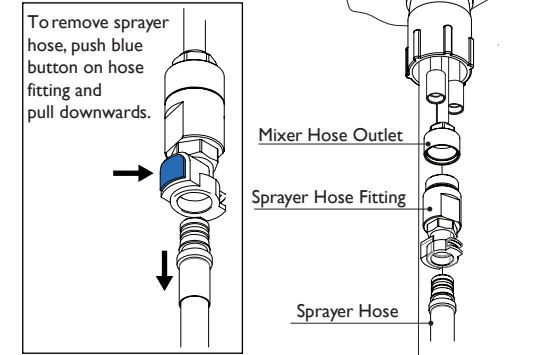

4

Attach the Counter Weight to the Sprayer Hose with the two screws supplied. Adjust the Counter Weight to approximately 200mm from the bottom of the Sprayer Hose.

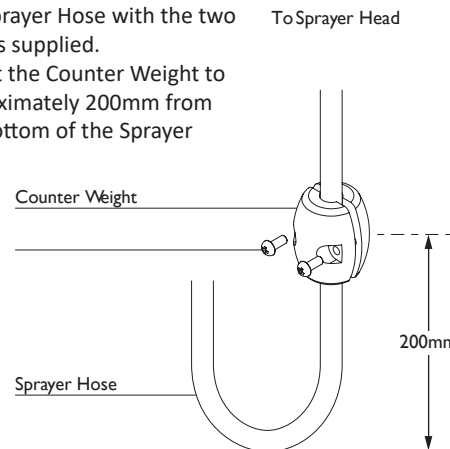

5

Connect Hoses to the Mixer Inlets. Ensure that the Red Marked Hot Water Hose is connected to the inlet that is marked with Red Indicator Tape.

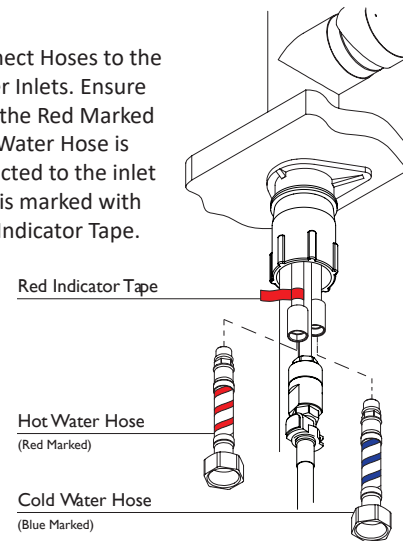

6

Connect Hoses to water supply.

CHECK AND TEST FOR LEAKS

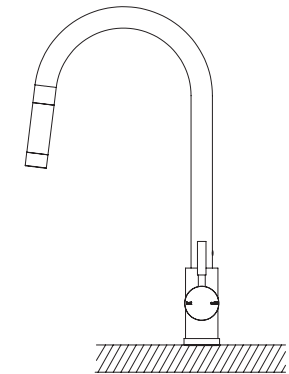

recommended working pressure
150-500kPa

maximum hot water temperature
75 degrees



NOTE:

- If the pressure exceeds or is likely to exceed 550kpa, an approved pressure limiting device must be installed.
- Flush out all pipe work prior to installation.
- If the water temperature exceeds 75°C, an approved tempering valve must be fitted.
- Installation should comply with Australian standard AS3500.1 or relevant local authority requirements. Showers may not be suitable for use within:
 - Gravity-fed water systems

- Some instantaneous hot water systems; or
 - Pressure supply less than 150kPa;
- NOTE: The 500kPa maximum water supply pressure does not apply to fire service outlets.

Failure to comply with the above may void all warranties.

WARRANTY:

Please refer to the full warranty statement enclosed with the product before installing.

MAINTENANCE AND CARE:

- Chrome plated surfaces should be cleaned with mild liquid detergent or soap and water.
- Do not use cream cleaners or citrus based cleaning products, as they are abrasive.
- Use of unsuitable cleaning agents may damage the surface. Any damage caused in this way will not be covered by warranty.

DISCLAIMER:

While we aim to ensure the specifications shown are correct at the time of printing, we reserve the right to make modifications without prior notice. Always use the physical product measurements for mark-ups and roughing-in as the line drawing shown may differ from the actual product over time.

*All measurements are shown in millimeters.