

BREACH SET-UP

Ensure that seats in the Breach are in good condition and are free of foreign objects.

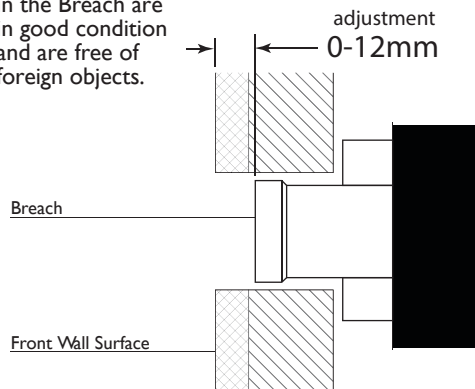

1

- Apply Teflon Tape to Threaded Elbow.
- Firmly screw the Swivel Flange onto Threaded Elbow.
- Seat the Small Bearing inside the Swivel Flange.
- Push Spout Tail into the Swivel Flange.
- Fasten Grub Screw until tight and then loosen a quarter turn.

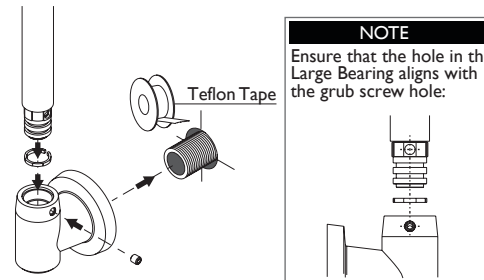

2

- Fit Fibre Washer to Spindle and then firmly screw Spindle into the Breach.

Tighten Spindle with a spanner.

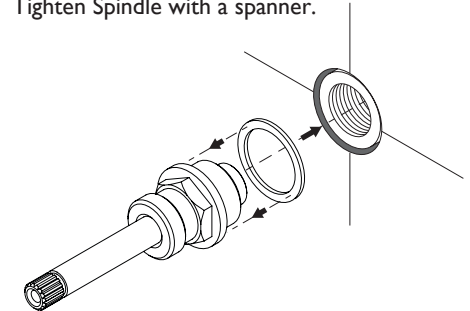

3

- Firmly screw the Flange onto Spindle.

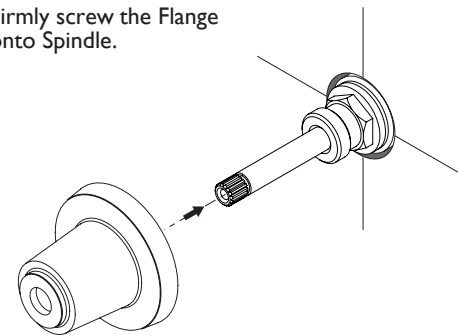

4

- Fit the Handle Screw over the Spindle Arm.
- Fit the C-Clip into the groove in the Spindle Arm.
- Fit the O-Ring then the Handle onto the Spindle Arm.
- Fasten the Handle Screw using the Spanner provided.

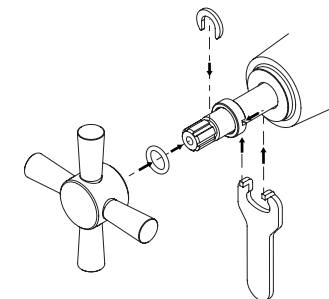

recommended working pressure
150-500kPa

maximum hot water temperature



75 degrees

NOTE:

- If the pressure exceeds or is likely to exceed 550kpa, an approved pressure limiting device must be installed.
- Flush out all pipe work prior to installation.
- If the water temperature exceeds 75°C, an approved tempering valve must be fitted.
- Installation should comply with Australian standard AS3500.1 or relevant local authority requirements. Showers may not be suitable for use within:
 - Gravity-fed water systems

- Some instantaneous hot water systems; or
 - Pressure supply less than 150kPa;
- NOTE: The 500kPa maximum water supply pressure does not apply to fire service outlets.

Failure to comply with the above may void all warranties.

WARRANTY:

Please refer to the full warranty statement enclosed with the product before installing.

MAINTENANCE AND CARE:

- Chrome plated surfaces should be cleaned with mild liquid detergent or soap and water.
- Do not use cream cleaners or citrus based cleaning products, as they are abrasive.
- Use of unsuitable cleaning agents may damage the surface. Any damage caused in this way will not be covered by warranty.

DISCLAIMER:

While we aim to ensure the specifications shown are correct at the time of printing, we reserve the right to make modifications without prior notice. Always use the physical product measurements for mark-ups and roughing-in as the line drawing shown may differ from the actual product over time.

*All measurements are shown in millimeters.