

### Features & Benefits

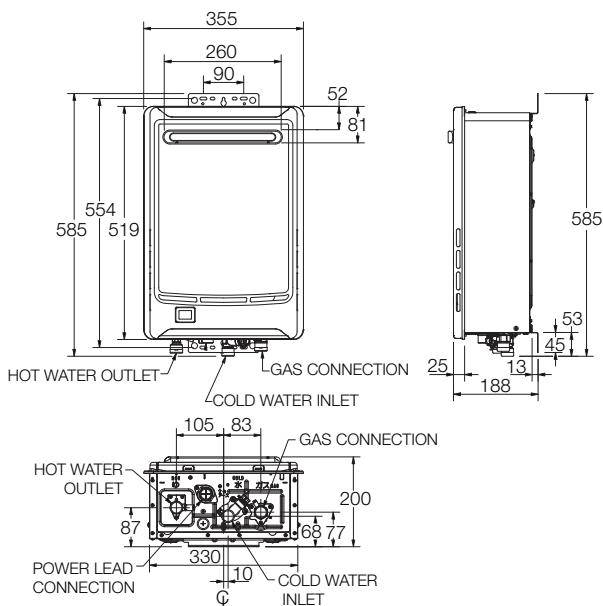

- 16 L/min continuous hot water delivery @ 25°C rise
- Remote Temperature Controller options
- 50°C models available (876A16), requiring no tempering valve<sup>3</sup>
- LED display for easy fault diagnosis
- Natural gas & Propane models
- Accessories: Recess Box 299427  
Security Cage 299867  
Wall Mount Security Kit 299868
- 12 year heat exchanger warranty<sup>1</sup>



MODEL	876A16 874A16
Min. Operating Flow rate (L/min)	2.0
Nom. Gas Consumption (MJ/hr)	126
Max Water Supply Pressure (kPa)	1000
Min Water Supply Pressure (kPa)	120
Water Connections	R <sup>3</sup> / <sub>4</sub>
Gas Connection	R <sup>3</sup> / <sub>4</sub>
Approx. Weight (Empty) kg	16



Scan code for details & installation instructions

