

COMMERCIAL HEAT PUMP

Heat water using free energy from the air using our Air to Water models, or, heat water using waste heat from a chiller using our Water to Water models.

CASE STUDY

CURTIN UNIVERSITY PERTH, WA

Challenge

Western Australia's Curtin University has embarked on the delivery of their Master Plan, which will transform the Perth campus into a collaborative innovation precinct.

To reduce ongoing operational and running costs Stantec chose to work with Rheem on a central plant system.

By installing high efficiency Rheem Air to Water Commercial Heat Pumps, the

"Exchange" building achieved 6 Star certification.

Hot Water Solution

Across the entire precinct, Rheem supplied:

- 4 x Rheem 35kW Air to Water Commercial Heat Pumps
- 4 x Rheem 16kW Air to Water Commercial Heat Pumps
- 4 x BMS monitoring
- 29 x Rheem 1000L RT Series Storage Tanks
- 3 x Rheem Tankpak Deluxe gas water heaters



AIR TO WATER HEAT PUMP

FOR WHERE ENERGY EFFICIENCY IS ESSENTIAL



HEAT PUMP



HOT WATER TO 65°C¹



SAVE UP TO 75% ENERGY



FLEXIBLE, USES CAR PARK AIR

65°C hot water in a super-efficient, super-compact package.

HIGHLY EFFICIENT

On average, 25% of the operating cost of an electric water heater. Delivers hot water up to 65°C¹, with a system Coefficient of Performance (COP) of up to 4.2². This makes it substantially cheaper to run than electric, natural gas or propane. Highly efficient option for fuel redundancy. Heat pumps can also be used as a preheat to other boost fuel types.

GREEN POINTS

Adds to the green points from End of Trip Facilities. The heat pump is designed to draw it's air from and discharge within basement car parks without flueing, unlike gas systems therefore reducing CO₂ emissions.

MULTIPLE INSTALLATION OPTIONS

Designed for both vertical or horizontal discharge options, with a discharge fan option available in both ducted and non-ducted versions. Horizontal discharge models can also be stacked two high to reduce plant footprint (suffix 'S').

SUITS MOST AUSTRALIAN CLIMATES

Manufactured by Rheem in Australia and supported by a nationwide in-house Service team, with local technical support. Automatic defrost allows continued performance in low ambient temperature conditions by diverting a portion of the hot refrigerant to the evaporator coil to melt any ice which may form. In addition, the evaporator

is fully dipped with Rheem Kote(R) to provide extra protection in corrosive atmospheres, and the unit has been tested in ambient conditions as high as 45°C.

- Rheem iQ control provides on board diagnostics, system configuration and optional high level BMS connectivity via Modbus or BACnet



Typical installation

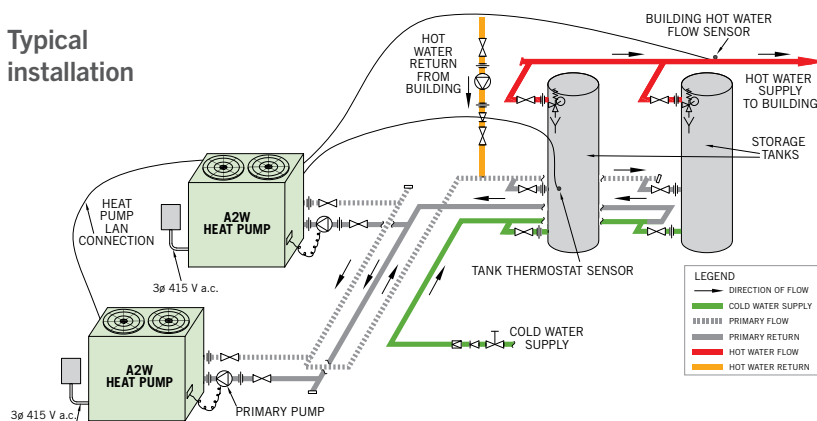

*For full terms and conditions contact Rheem or visit www.rheem.com.au/warranty



TECHNICAL DATA

AIR TO WATER 16kW MODEL

Horizontal Discharge Models

- 953016H0 – Non Ducted
- 953016HS – Non Ducted stackable
- 952016H0 – Ducted
- 952016HS – Ducted stackable

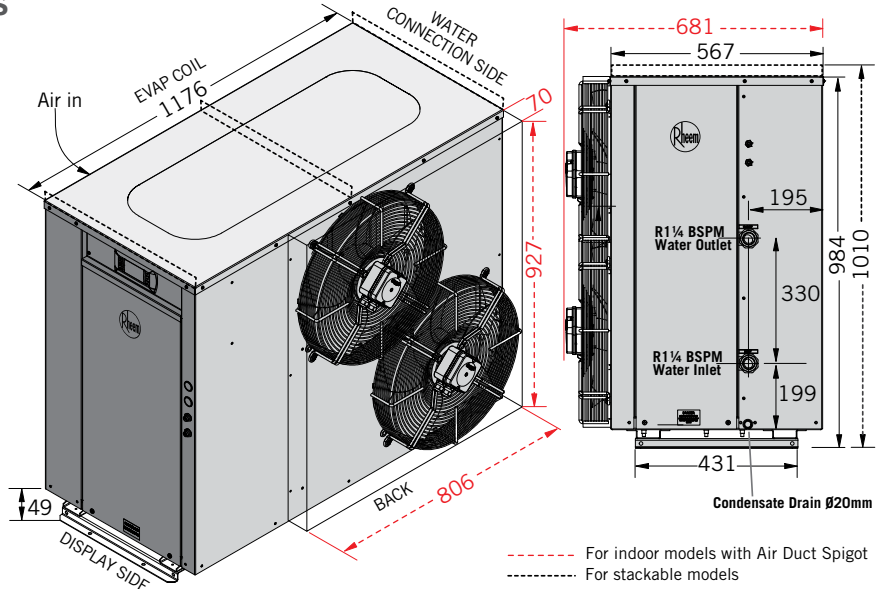

Vertical Discharge Models

- 95301600 – Non Ducted
- 95201600 – Ducted

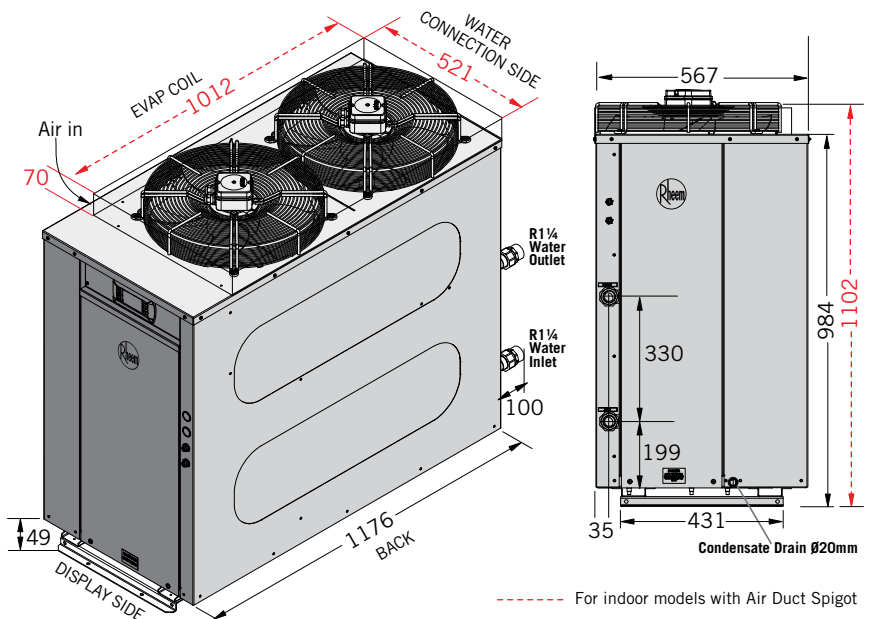

TECHNICAL DATA

AIR TO WATER 16KW MODEL			
Product data		Ducted Exhaust	Non Ducted Exhaust
Heating Capacity ²	kW	17.83	17.83
Power Input ²	kW	4.26	4.26
Coefficient of Performance COP ²		4.2	4.2
Recovery @ 50°C Rise ²	L/hr	300	
Operating Range (ambient)	°C	0-45	
Maximum DHW Temperature	°C	65	
Refrigerant		R134a	
Hot Water Side			
TPR Valve Setting (VE/RT)	kPa	1,000/850	
ECV Setting (VE/RT) ³	kPa	850/700	
Maximum Water Supply Pressure			
- Without ECV (VE/RT)	kPa	800/680	
- With ECV (VE/RT)		650/550	
Design Flow Rate	L/s	1.1	
Design Pressure Drop	kPa	33	
Heat Exchanger Design		316 Stainless Steel DWBP	
Air Side			
Air Flow (at maximum static pressure)	L/s	1600	
Maximum Static Pressure	Pa	80	20
Minimum Ventilation per inlet and outlet	m ²	1	
Electrical Connection			
Power Supply		3 Phase / 380-415V / 50 Hz	
Max Current per Phase (running, incl pump)	Amps	17.06	15.22
Minimum Circuit Breaker size (per phase)	Amps	20	
Installation Data			
Approx Weight Empty	kg	120	
Approx Weight Full	kg	125	
Storage per Heat Pump	L	400 – 4,000	
Sound Pressure Level	dBa	59 @ 3m	
Clearances			
Eva Coil Side	mm	500	
Back (vertical discharge models)	mm	Nil	
Back (horizontal discharge models)	mm	1,200	
Display Side	mm	850	
Water Connection Side	mm	500	
Top (vertical discharge models)	mm	1,200	
Top (horizontal discharge models)	mm	Clearance above unit required for service personnel to stand	

PUMP AND PIPE SIZING CHART				
Number of Heat Pumps in Parallel	1	2	3	4
Primary Pump	CM3-2			
Branch Size	40			
Header Size	40	50	65	80

Note: Header pipe sizing is based on a total length of 40m of primary flow and return piping and 20 bends, excluding equa-flow manifolds on storage tanks and heat pumps @ 1.2m/sec velocity. One pump per Heat Pump.

ACCESSORIES			
Storage Tank	Pump	BMS Card	LAN Cable
410L (VE)	CM 3-2 366084	17520 BACnet TCP/IP	17534
1000L to 5000L (SS)		17521 BACnet MS/TP	
		17522 Modbus RS485	

¹ When ambient temperature is not likely to drop below 10°C during operation.

² 20°C ambient/60%RH. 39°C water in / 45°C water out.

³ ECV not supplied with water heater.

TECHNICAL DATA

AIR TO WATER 35kW MODEL

Horizontal Discharge Models

- 953035H0 – Non Ducted
- 953035HS – Non Ducted stackable
- 952035H0 – Ducted
- 952035HS – Ducted stackable

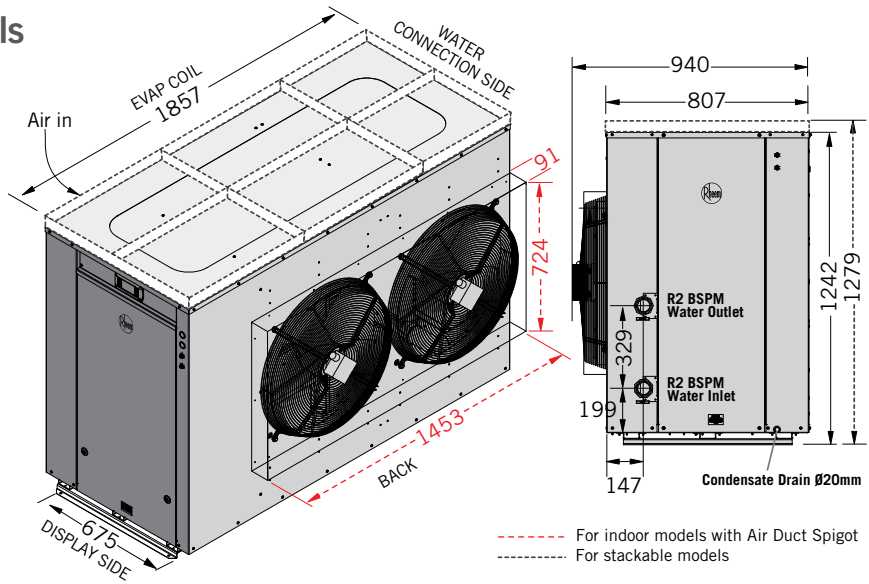

Vertical Discharge Models

- 95303500 – Non Ducted
- 95203500 – Ducted

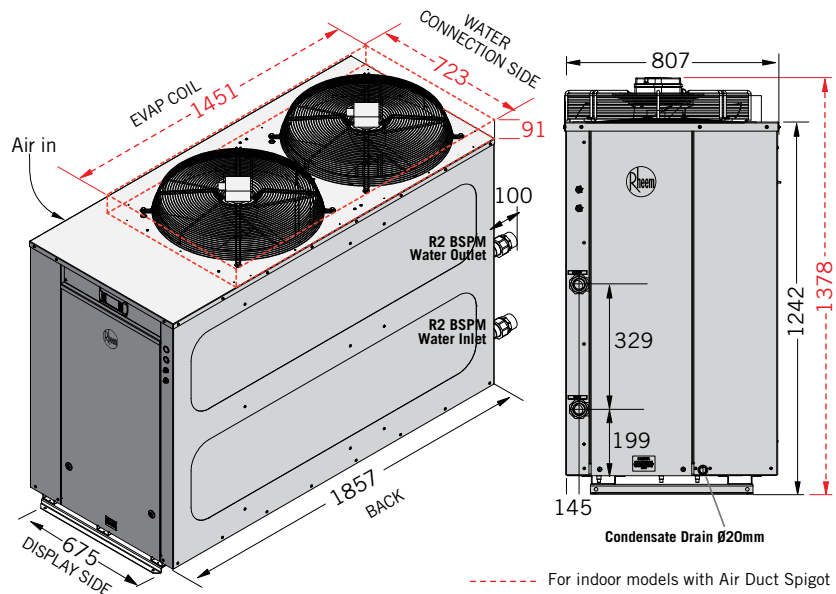

TECHNICAL DATA

AIR TO WATER 35KW MODEL			
PRODUCT DATA		Ducted Exhaust	Non Ducted Exhaust
Heating Capacity ²	kW	39.55	39.55
Power Input ²	kW	10.25	10.25
Coefficient of Performance COP ²		3.9	3.9
Recovery @ 50°C Rise ²	L/hr	680	
Operating Range (ambient)	°C	5-45	
Maximum DHW Temperature	°C	65	
Refrigerant		R134a	
Hot Water Side			
TPR Valve Setting (VE/RT)	kPa	1,000/850	
ECV Setting (VE/RT) ³	kPa	850/700	
Maximum Water Supply Pressure	kPa		
- Without ECV (VE/RT)		800/680	
- With ECV (VE/RT)		650/550	
Design Flow Rate	L/s	2.2	
Design Pressure Drop	kPa	40	
Heat Exchanger Design		316 Stainless Steel DWBP	
Air Side			
Air Flow (at maximum static pressure)	L/s	5,830	5,270
Maximum Static Pressure	Pa	80	20
Minimum Ventilation per inlet and outlet	m ²	1.93	
Electrical Connection			
Power Supply		3 Phase / 380-415V / 50 Hz	
Max Current per Phase (running, incl pump)	Amps	34.9	32.34
Minimum Circuit Breaker size (per phase)	Amps	40	
Installation Data			
Approx Weight Empty	kg	300	
Approx Weight Full	kg	310	
Storage per Heat Pump	L	400 – 8,000	
Sound Pressure Level	dBa	69 @ 3m	
Clearances			
Evap Coil Side	mm	1,000	
Back (vertical discharge models)	mm	Nil	
Back (horizontal discharge models)	mm	2,000	
Display Side	mm	850	
Water Connection Side	mm	600	
Top (vertical discharge models)	mm	2,000	
Top (horizontal discharge models)	mm	Clearance above unit required for service personnel to stand	

PUMP AND PIPE SIZING CHART				
Number of Heat Pumps in Parallel	1	2	3	4
Primary Pump	Grundfos CM 10-1			
Branch Size	50			
Header Size	50	80	100	100

Note: Header pipe sizing is based on a total length of 40m of primary flow and return piping and 20 bends, excluding equal-flow manifolds on storage tanks and heat pumps @ 1.2m/sec velocity. One pump per Heat Pump.

ACCESSORIES			
Storage Tank	Pump	BMS Card	LAN Cable
410L (VE)	CM 10-1 366094	17520- BACnet TCP/IP	17534
1000L to 5000L (SS)		17521- BACnet MS/TP	
		17522- Modbus RS485	

¹ When ambient temperature is not likely to drop below 10°C during operation.

² 20°C ambient/60%RH. 39°C water in / 45°C water out.

³ ECV not supplied with water heater.

TECHNICAL DATA

AIR TO WATER 16KW MODEL RECOVERY

Ambient Temperature °C	0	5	10	15	20	25	30	35	40	45
Output (kW)	11.18	12.85	14.51	16.17	17.83	19.76	21.69	23.62	25.55	27.48
Recovery – Litres per hour										
20°C rise	481	553	624	695	767	850	933	1016	1099	1182
25°C rise	385	442	499	556	613	680	746	813	879	945
30°C rise	320	368	416	464	511	566	622	677	732	788
35°C rise	274	315	356	397	438	485	532	580	627	675
40°C rise	240	276	312	348	383	425	466	508	549	591
45°C rise	214	246	277	309	341	378	415	451	488	525
50°C rise	N/A	221	250	278	307	340	373	406	439	473
55°C rise	N/A	201	227	253	279	309	339	369	400	430

AIR TO WATER 35KW MODEL RECOVERY

Ambient Temperature °C	0	5	10	15	20	25	30	35	40	45
Output (kW)	22.63	26.60	29.07	33.96	39.55	46.04	49.05	52.11	54.57	56.28
Recovery – Litres per hour										
20°C rise	973	1144	1250	1460	1701	1980	2109	2241	2347	2420
25°C rise	778	915	1000	1168	1361	1584	1687	1793	1877	1936
30°C rise	649	763	833	974	1134	1320	1406	1494	1564	1613
35°C rise	556	654	714	834	972	1131	1205	1280	1341	1383
40°C rise	487	572	625	730	850	990	1055	1120	1173	1210
45°C rise	432	508	556	649	756	880	937	996	1043	1076
50°C rise	N/A	458	500	584	680	792	844	896	939	968
55°C rise	N/A	416	455	531	618	720	767	815	853	880

16 kW A2W COP and Heating Capacity

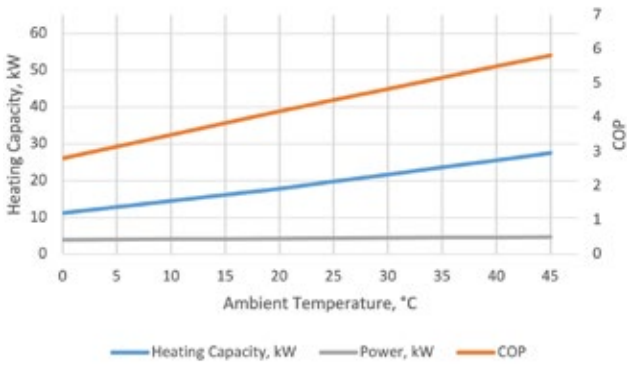

35 kW A2W COP and Heating Capacity

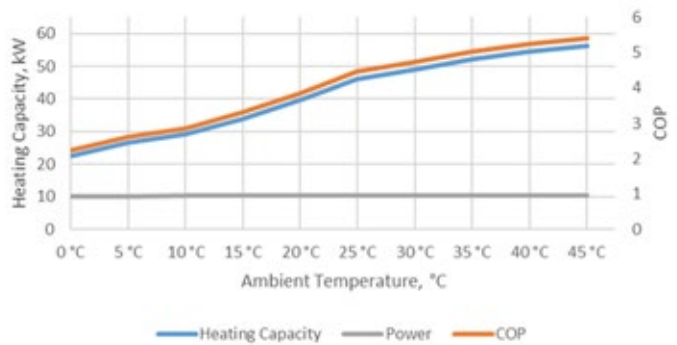

WATER TO WATER HEAT PUMP

FOR WHERE ENERGY EFFICIENCY IS ESSENTIAL



HEAT PUMP



WASTE HEAT RECOVERY



COMPACT



UP TO 7.0 COP EFFICIENCY

The Rheem Water to Water (W2W) range.

Includes units using readily available R134a for hot water heating up to 65°C, with a minimum entering water temperature on the building chiller loop of 12°C, or higher temperatures on the condenser loop, with the units being compact and suitable for indoor or outdoor installation.

EFFICIENCY

The ability of these units to provide a dual efficiency sees combined COPs of up to 7.0¹. The efficiency in hot water production is up to 4.0¹ and this leads to substantial savings in energy use and heating cost. The savings are magnified where the cooling by-product lessens a building's chilling load. COP in cooling are up to 3.0¹.

RETURN ON INVESTMENT

High COP of this product provides enormous savings compared to gas and electric heating systems which results in a very favourable return on investment making the W2W HP both a sound environmental and financial investment.

MORE KEY FEATURES

- Water Mark certified 316L stainless steel, double-wall brazed plate heat exchanger on domestic hot water side
- Multiple safeties including low temperature freeze protection and flow switch on the chilled water side
- Full commercial construction with marine grade aluminium case
- Rheem iQ control provides on board diagnostics, system configuration and optional high level BMS connectivity via Modbus or BACnet



Typical installation

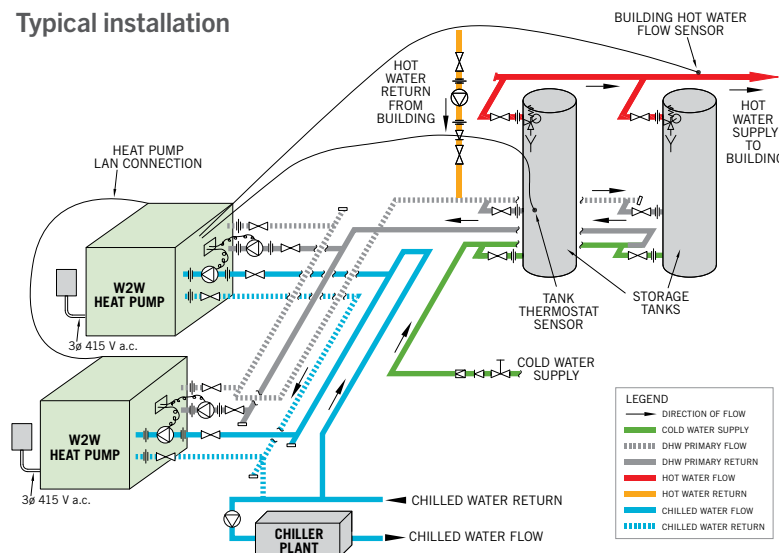

TECHNICAL DATA

15kW Model

95401500 - non-stackable 9540150S - stackable

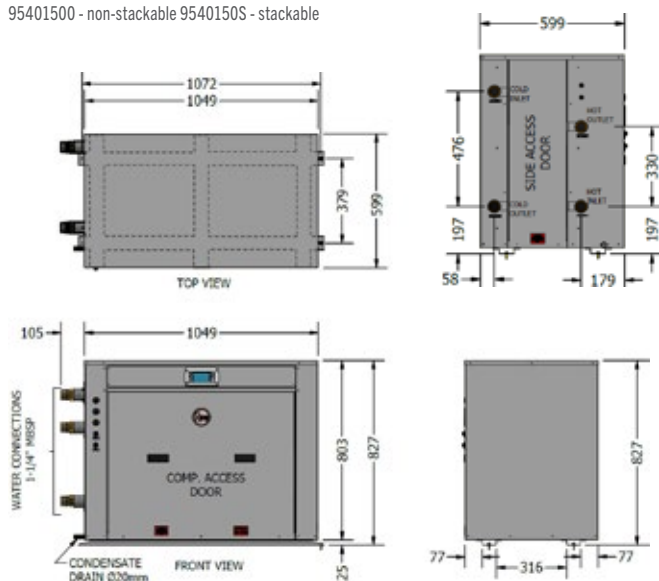

35kW Model

95403500 - non-stackable 9540350S - stackable

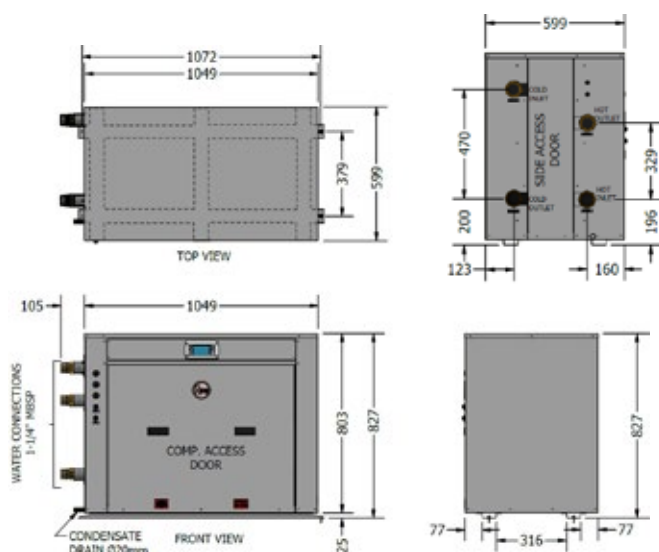

MODEL	15kW	35kW
Nominal Heating Capacity at 12°C Cold Water Temperature ¹	15kW	34.75kW
Nominal Cooling Capacity at 12°C Cold Water Temperature ¹	11.3kW	25.9kW
Nominal Heating Capacity at 35°C Cold Water Temperature ²	27.65kW	64.84kW
Power Input kW ¹	3.69kW	8.75kW
Coefficient of Performance (Heating) ¹ at 12°C	4.06	3.97
Coefficient of Performance (Cooling) ¹ at 12°C	3	3
Coefficient of Performance (Heating) ² at 35°C	6.97	7.1
Maximum DHW Temperature	65°C	
Refrigerant	R134a	
Hot Water Side		
TPR Valve Setting (VE/SS)	1000/850 kPa	
ECV Setting (VE/SS) ³	850/700 kPa	
Maximum Water Supply Pressure	800/680 kPa	
– Without ECV (VE/SS) ³	680/550 kPa	
– With ECV (VE/SS) ³		
Hot Water Side Flow Rate	1.1L/s	2.2L/s
Heat Exchanger Heating Design	316L Stainless steel – Double wall brazed plate	
Design Heating Temperature Difference	6°K	
Design Pressure Drop	40kPa	
Cold Water Side		
Maximum Water Supply Pressure	2450kPa	
Cold Water Side Flow Rate	1.1L/s	1.85L/s
Heat Exchanger Cooling Design	316L Stainless steel – Single wall brazed plate	
Design Cooling Temperature Difference	5°K	
Design Pressure Drop	40kPa	
Electrical Connection	3 Phase / 415V / 50Hz	
Max Current per Phase (running, incl pumps)	13.96	29.94
Minimum Circuit Size (per phase)	20A	40A
Sound Pressure Level	59dBa @ 3m	
Approx Weight Empty	100kg	120kg
Approx Weight Full	105kg	125kg
Storage per Heat Pump	400L to 4000L	400L to 8000L
Clearances		
Front	850mm	
Back	Nil mm	
Water Connections Side	500mm	
RHS Side	Nil mm	
Top (clearance above unit required for service personnel to stand)	350mm	

¹ Rating Conditions: Heating 39°C water in, 45°C water out, 51°C SCT, Cold 12°C water in, 7°C water outlet, 2°C SST.
² Rating Conditions: Heating 39°C water in, 45°C water out, 51°C SCT, Cold 35°C water in, 29.5°C water outlet, 10°C SST.
³ ECV not supplied with water heater

ACCESSORIES			
Storage Tank	Pump	BMS Card	LAN Cable
410L (VE)	2 x CM 3-2 (16kW)	17520-BACnet TCP/IP	17534
1000L to 5000L (SS)	2 x CM 10-1 (35kW)	17521-BACnet MS/TP	
		17522-Modbus RS485	

TECHNICAL DATA

PUMP AND PIPE SIZING CHART									
No. of Heat Pumps in Parallel	15kW				35kW				
	HOT SIDE				HOT SIDE				
	1	2	3	4	1	2	3	4	
Pump	Grundfos CM 3-2				Grundfos CM10-1				
Branch Size (mm)	40				50				
Header Size (mm)	40	50	65	80	50	80	100	100	
No. of Heat Pumps in Parallel	COLD SIDE				COLD SIDE				
	1	2	3	4	1	2	3	4	
Pump	Grundfos CM 3-2				Grundfos CM10-1				
Branch Size (mm)	40				50				
Header Size (mm)	40	50	65	80	50	80	100	100	

RECOVERY – 15 KW W2W								
Ambient Temperature °C	12	14	16	18	20	25	30	35
Output (kW)	14.99	16.46	16.97	18.06	19.21	22.39	26.04	27.65
Recovery – Litres per hour								
20°C rise	645	708	730	777	826	963	1120	1189
25°C rise	516	566	584	621	661	770	896	951
30°C rise	430	472	486	518	551	642	746	793
35°C rise	368	404	417	444	472	550	640	679
40°C rise	322	354	365	388	413	481	560	594
45°C rise	286	315	324	345	367	428	498	528
50°C rise	258	283	292	311	330	385	448	476
55°C rise	234	257	265	282	300	350	407	432

RECOVERY – 35 KW W2W								
Ambient Temperature °C	12	14	16	18	20	25	30	35
Output (kW)	34.75	38.21	39.44	42.00	44.72	52.25	60.98	64.84
Recovery – Litres per hour								
20°C rise	1494	1643	1696	1806	1923	2247	2622	2788
25°C rise	1195	1314	1357	1445	1538	1797	2098	2231
30°C rise	996	1095	1131	1204	1282	1498	1748	1859
35°C rise	854	939	969	1032	1099	1284	1498	1593
40°C rise	747	822	848	903	961	1123	1311	1394
45°C rise	664	730	754	803	855	999	1165	1239
50°C rise	598	657	678	722	769	899	1049	1115
55°C rise	543	597	617	657	699	817	954	1014

15 kW W2W COP and Heating Capacity

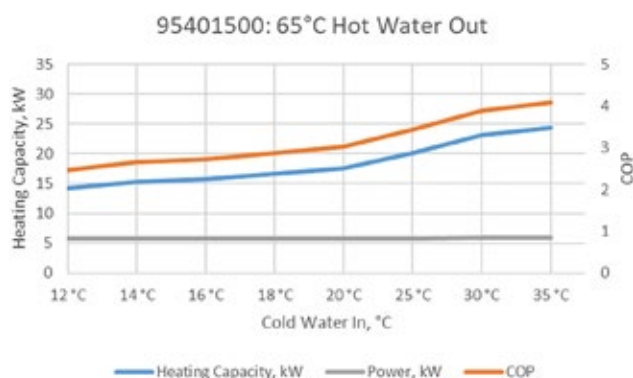

35 kW W2W COP and Heating Capacity

