

RHEEM ULTRANAMEL® ELECTRIC WATER HEATERS PRODUCT DATA

RHEEM ULTRANAMEL® ELECTRIC WATER HEATERS



MODEL		80L	125L	160L	250L	315L	400L
Rheem Single Element		491080	491125	491160	491250	491315	491400
Rheem Twin Element				492160	492250 ²	492315	492400
RheemPlus®			421125	421160 ⁴	421250 ⁴	421315 ⁴	
Hot Water Delivery	Litres	80	125	160	250	315	400
Boost Capacity (twin element models)	Litres	-	-	45	50	50	90
kW Rating	1.8	✓	✓	✓	✓	-	-
	2.4	-	-	✓	-	-	-
	3.6	✓	✓	✓	✓	✓	✓
	4.8	-	-	-	✓	✓	✓
Relief Valve Setting	kPa	1400	1400	1400	1000	1000	1000
Expansion Control Valve (kPa)	kPa	1200	1200	1200	850	850	850
Max Water Supply Pressure:							
with ECV (kPa)	kPa	960	960	960	680	680	680
without ECV (kPa)	kPa	1120	1120	1120	800	800	800
Water Hot and Cold Connections	Rp 3/4	Rp 3/4	Rp 3/4	Rp 3/4	Rp 3/4	Rp 3/4	Rp 3/4
Dimensions							
A	mm	945	1340	1610	1395	1640	1840
B	mm	480	480	480	640	640	690
C	mm	515	515	515	680	680	730
D	mm	702	1102	1332	1117	1317	1479
E	mm	64	64	104	73	113	121
F	mm	66	66	66	103	103	105
G - Twin element models	mm	-	-	1081	988	1228	1323
H	degrees	24	24	23	32	32	30
J	degrees	60	60	58	88	88	83
K	-	-	545	545	705	705	-
L	-	-	183	183	262	262	-
M	degrees	-	-	58	92	92	97
Weight (packaged)	kg	38	52	60	82	97	120

¹ Rheem VE Electric warranty 12 Years on Cylinder, 1 Year Parts & Labour warranty on all components. For Domestic (non-Commercial) installations. Conditions apply. See the Warranty set out in the Owner's Guide & Installation Instructions or view at www.rheem.com.au/warranty

² 50°C factory pre-set models supply hot water to a maximum 50°C at all outlets in accordance with AS3498. Some applications may require tempering, refer to AS/NZS3500.4

³ Available in 3.6 & 4.8 element rating only.

⁴ Available in 3.6 element rating only.

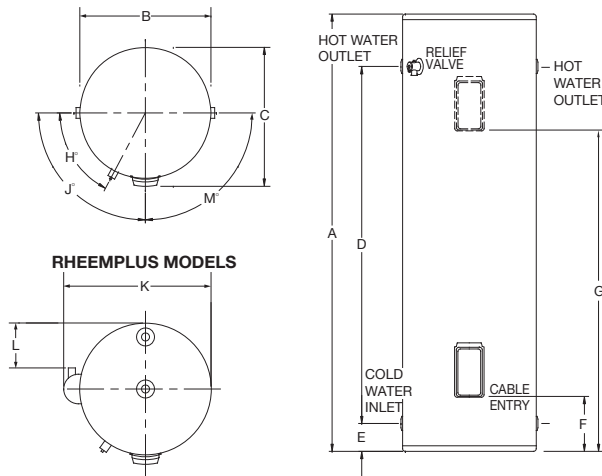

Rheem Australia Pty Ltd.
1 Alan Street, Rydalmere, New South Wales 2116, Australia
PO Box 7508, Silverwater NSW 2128 Australia
www.rheem.com.au

* Registered Trademark of Rheem Australia Pty Ltd.
™ Trademark of SAI Global.
™ Trademark of Rheem Australia Pty Ltd.



Rheem-REHE242; July 2018

ELECTRIC |
 50°C LIMITED MODELS AVAILABLE |
 1-9 PEOPLE |
 80L-400L DELIVERY |
 DUAL HANDED |
 12 YEAR CYLINDER WARRANTY!



NEW 12 Year Cylinder Warranty Range
Featuring the REAL difference



THE REAL DIFFERENCE

Rheem electric water heaters are designed and manufactured by Rheem, Australia's No.1. This improved 80L – 400L range features the 'REAL' difference, with enhancements combining to deliver maximum performance and reliability, backed by the 12 year cylinder warranty and over 80 years of local manufacturing experience.



RELIABILITY – Rheem '491/492/421' series electric water heaters are built to last. The cylinder dome top has been redesigned to make it even stronger, and better able to withstand the effects of high temperature and pressure.

ANODE – A thicker 27mm diameter (up from 21mm) black cap anode is fitted as standard. This provides more physical material to help protect the cylinder for longer.

Specialty blue cap anode models feature a 21mm diameter anode (up from 17mm).

An anode support secures the anode in place, preventing it swinging in the tank and causing damage during transport and handling.



Anode
Thicker 27mm diameter 'black cap' anode protects the cylinder for longer



Anode support
Secures the anode in place, preventing damage

ENAMEL – Exclusive Rheem Ultraname® Class Y enamel is more durable than domestic grade Class X enamels, and being less soluble can prolong the life of the water heater.

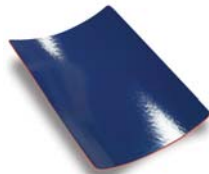

Enamel Coating
Rheem Ultraname®
Class Y enamel

LOCAL – Rheem 80L – 400L products are made right here in Australia. Rheem is a committed Australian manufacturer, dedicated to providing the best products and knowhow gained from over 80 years of local manufacturing experience.



RHEEMPLUS®

RheemPlus® is the perfect choice for new homes or when replacing existing water heaters.

RheemPlus® stores water above 60°C yet delivers water not exceeding 50°C so there's no need to install a tempering valve, making installations quicker and easier for the plumber and safer for the home owner.

- Tempering valves not required*
- Adjustable to deliver 50°C water at the tap
- Fast and easy installation
- Left handed fittings only (not dual handed)
- Neat appearance
- Mains pressure at multiple taps

KEY FEATURES

- **Easy retrofit**
Common footprint and fitting locations with existing Rheem water heaters ensures an easy changeover
- **Commercial Grade enamel**
Exclusive Rheem Ultraname® provides a tougher, longer lasting finish
- **Dual handed fittings**
Provides installation flexibility
- **Thicker sacrificial anodes**
More physical material provides additional protection for the cylinder
- **Twin Element models available**
Provides a daytime boost for high demand hot water use
- **Suit lower cost tariffs**
Large capacity water heaters are suitable for connecting to off peak overnight tariffs, for lower running costs
- **Manufactured in Australia**
Designed and built in Australia, with the knowhow of over 80 years of local manufacturing experience
- **Indoor/Outdoor**
Suitable for indoor or outdoor installations

