

SPHERE 800

LED MIRROR

PRODUCT CODE

S80

SPECIFICATIONS

WIDTH	800mm
HEIGHT	800mm
DEPTH	35mm
WEIGHT	11kg

FEATURES

Copper Free Mirror
LED Lighting (Adjustable Colour Temperature)
Backlit
Touch Sensor

LIGHTING SPECIFICATIONS

CCT	2700K - 6500K
CRI	>80

INSTALLATION

Wall mount
Hardwire
Input voltage: 220-240v 50Hz

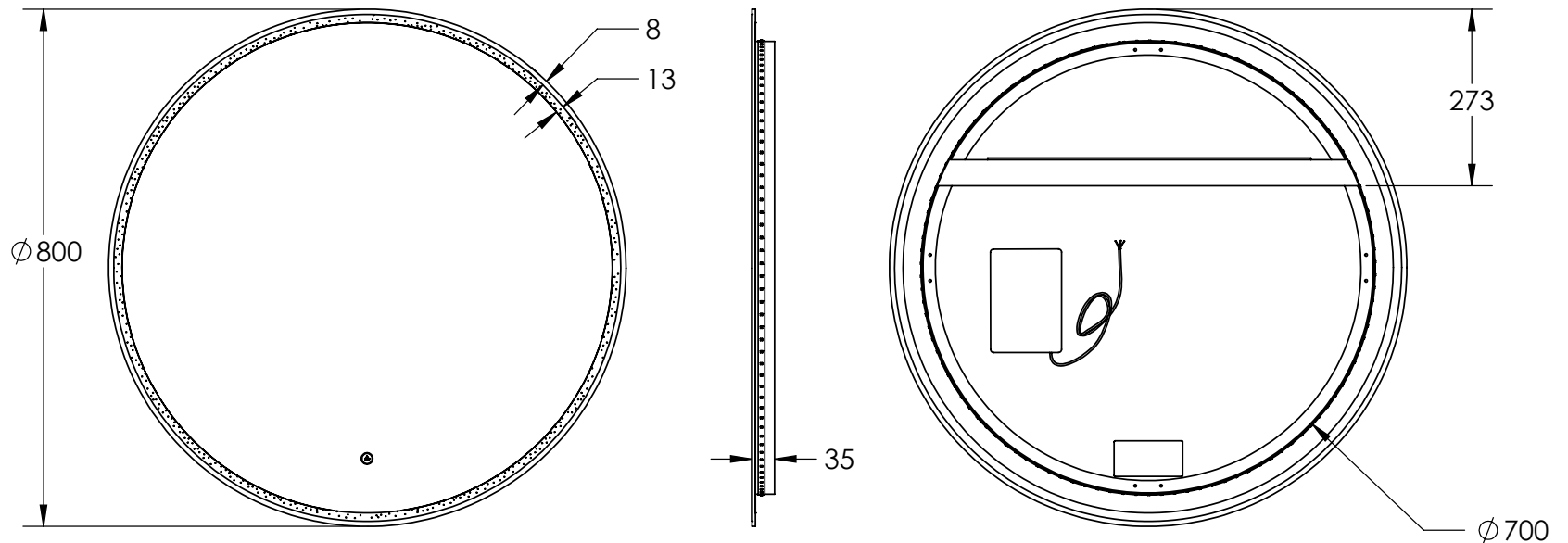

Disclaimer: All LED Products requiring hardwiring must be installed by a licensed electrician in accordance with local regulations. Sizes are in mm and nominal and should be checked prior to installation. Actual colours may vary so please check colour samples before ordering. Installation is acceptance of our products. Installation of faulty, warped, chipped or damaged products will void our warranty.

Please check actual product in box for bracket type used

SPHERE 800

PRODUCT CODE

S80

LED MIRROR

SPECIFICATIONS

WIDTH	800mm
HEIGHT	800mm
DEPTH	35mm
WEIGHT	11kg

FEATURES

Copper Free Mirror
LED Lighting (Adjustable Colour Temperature)
Touch Sensor

LIGHTING SPECIFICATIONS

CCT	2700K - 6500K
CRI	>80

INSTALLATION

Wall mount
Hardwire
Input voltage: 220-240v 50Hz

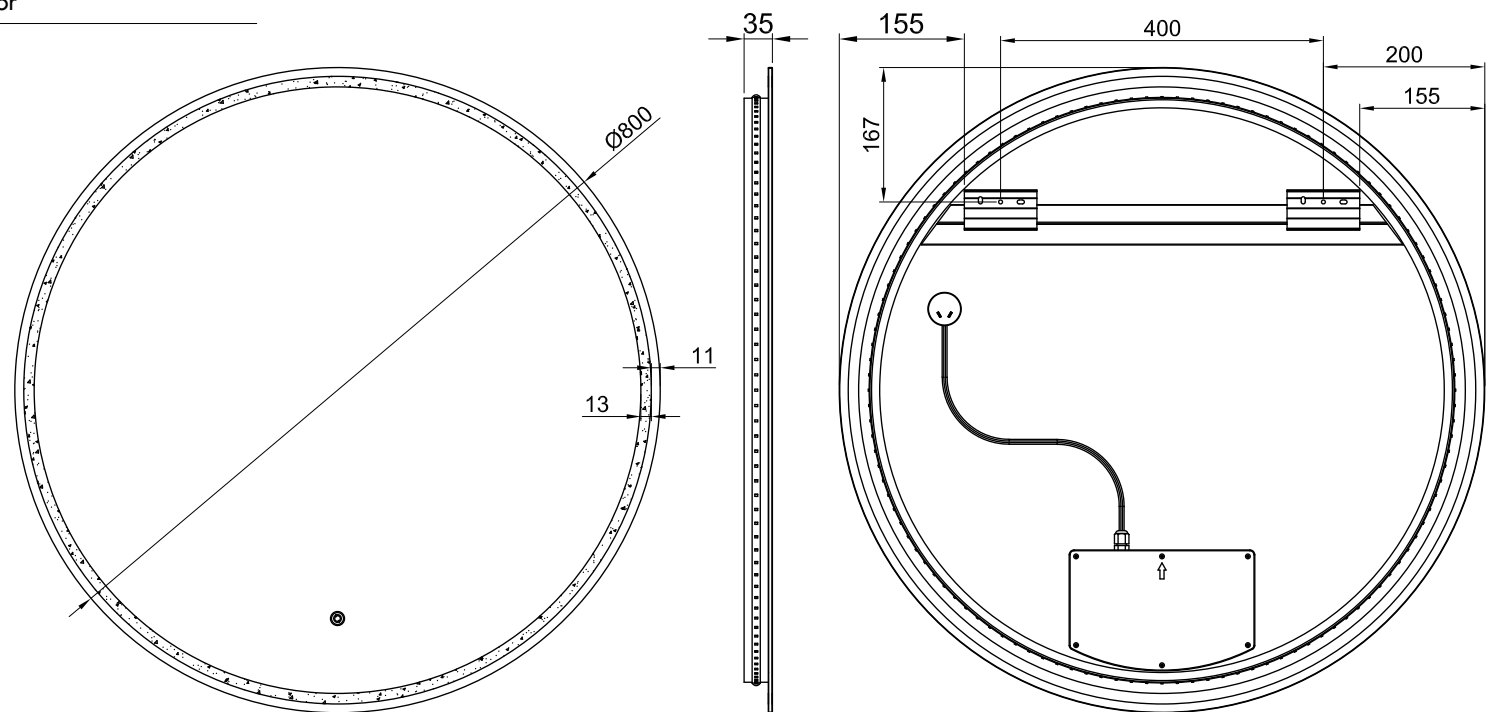

Disclaimer: All LED Products requiring hardwiring must be installed by a licensed electrician in accordance with local regulations. Sizes are in mm and nominal and should be checked prior to installation. Actual colours may vary so please check colour samples before ordering. Installation is acceptance of our products. Installation of faulty, warped, chipped or damaged products will void our warranty.

Please check actual product in box for bracket type used

SPHERE 800

LED MIRROR WITH ALUMINIUM FRAME

SPECIFICATIONS

WIDTH	810mm
HEIGHT	810mm
DEPTH	40mm
WEIGHT	12kg

LIGHTING SPECIFICATIONS

CCT	2700K - 6500K
CRI	>80

INSTALLATION

Wall mount
Hardwire
Input voltage: 220-240v 50Hz

FEATURES

Copper Free Mirror
LED Lighting (Adjustable Colour Temperature)
Frontlit
Touch Sensor
Coloured Aluminium Frame

FINISH		PRODUCT CODE
Brushed Brass		S80-BB
Brushed Nickel		S80-BN
Gun Metal		S80-GM
Matte Black		S80-MB
Matte White		S80-MW

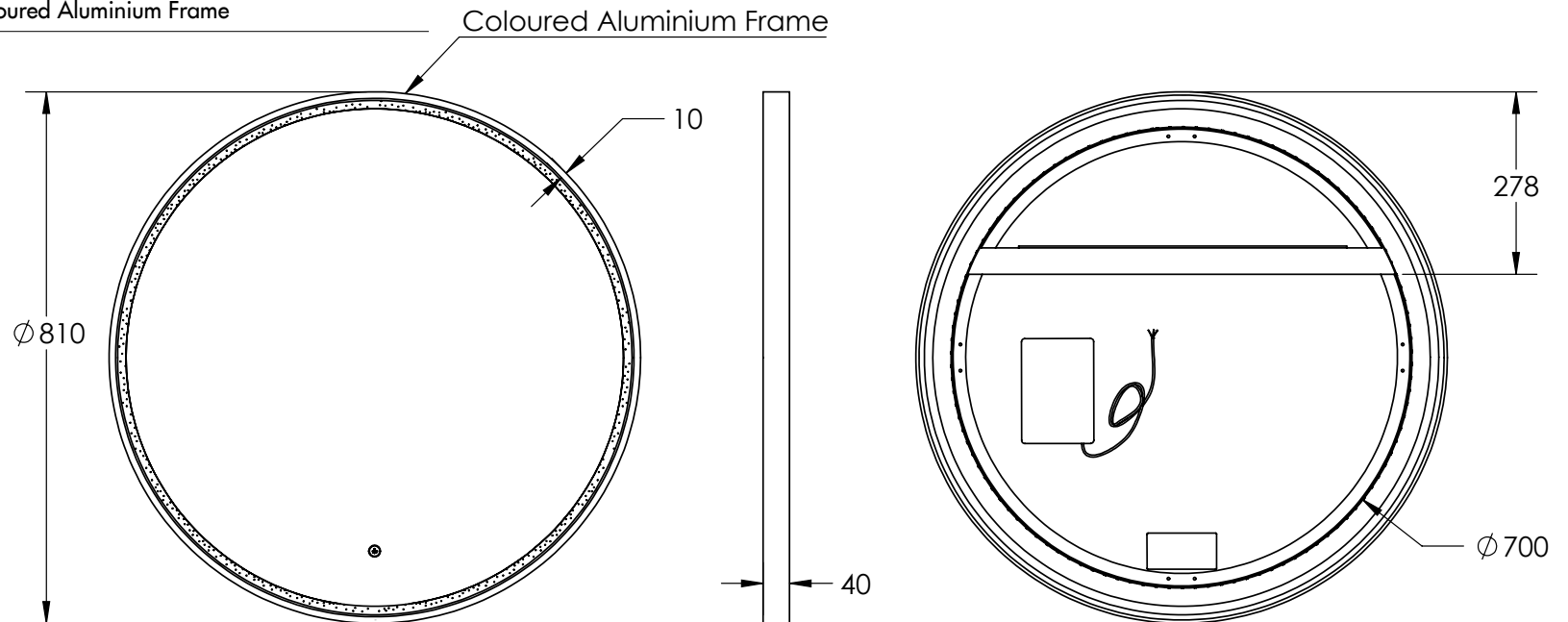

Disclaimer: All LED Products requiring hardwiring must be installed by a licensed electrician in accordance with local regulations. Sizes are in mm and nominal and should be checked prior to installation. Actual colours may vary so please check colour samples before ordering. Installation is acceptance of our products. Installation of faulty, warped, chipped or damaged products will void our warranty.

Please check actual product in box for bracket type used

SPHERE 800

LED MIRROR

SPECIFICATIONS

WIDTH	805mm
HEIGHT	805mm
DEPTH	40mm
WEIGHT	11kg

LIGHTING SPECIFICATIONS





CCT	2700K - 6500K
CRI	>80

INSTALLATION

Wall mount
Hardwire
Input voltage: 220-240v 50Hz

FEATURES

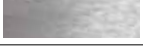
Copper Free Mirror
LED Lighting (Adjustable Colour Temperature)
Touch Sensor

FINISH	PRODUCT CODE
Brushed Brass 	S80-BB
Brushed Nickel 	S80-BN
Gun Metal 	S80-GM
Matte Black 	S80-MB
Matte White 	S80-MW

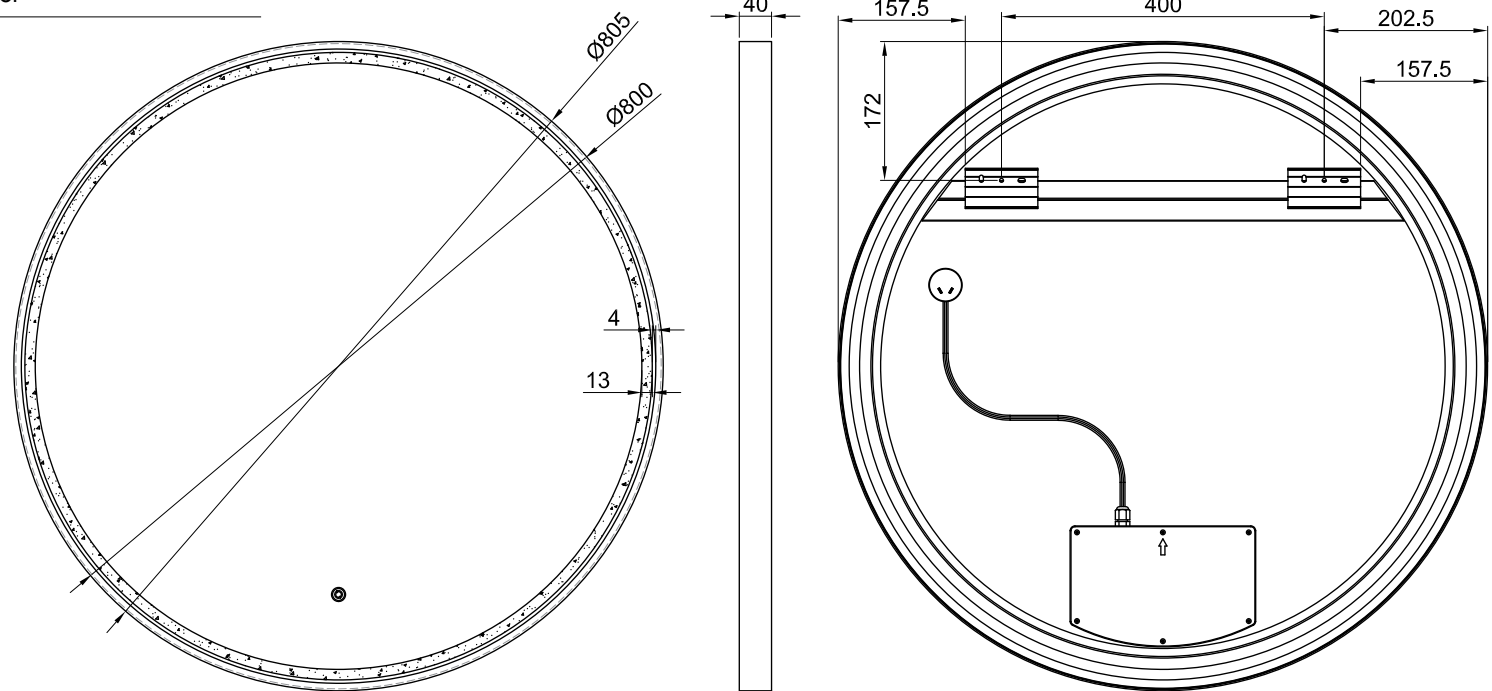

Disclaimer: All LED Products requiring hardwiring must be installed by a licensed electrician in accordance with local regulations. Sizes are in mm and nominal and should be checked prior to installation. Actual colours may vary so please check colour samples before ordering. Installation is acceptance of our products. Installation of faulty, warped, chipped or damaged products will void our warranty.