

SPHERE 800DB

LED MIRROR

PRODUCT CODE

S80DB

SPECIFICATIONS

WIDTH	800mm
HEIGHT	800mm
DEPTH	40mm
WEIGHT	11kg

FEATURES

Copper Free Mirror
LED Lighting (Adjustable Colour Temperature)
Backlit
Touch Sensor
Demister with 1 Hour Auto Cut-off
Bluetooth Speakers

LIGHTING SPECIFICATIONS

CCT	2700K - 6500K
CRI	>80

INSTALLATION

Wall mount
Hardwire
Input voltage: 220-240v 50Hz

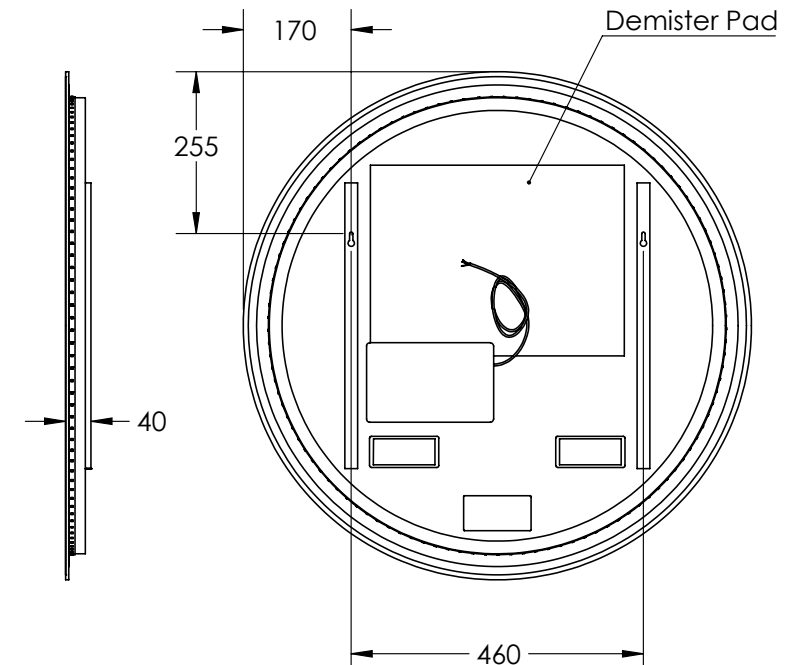
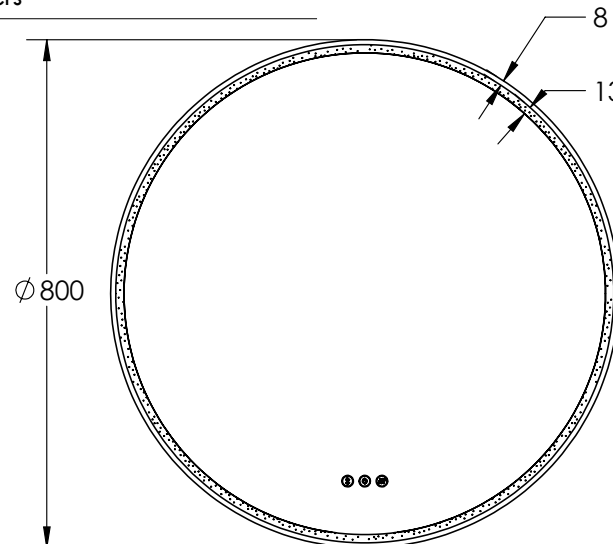

Disclaimer: All LED Products requiring hardwiring must be installed by a licensed electrician in accordance with local regulations. Sizes are in mm and nominal and should be checked prior to installation. Actual colours may vary so please check colour samples before ordering. Installation is acceptance of our products. Installation of faulty, warped, chipped or damaged products will void our warranty.

SPHERE 800DB

LED MIRROR

PRODUCT CODE

S80DB

SPECIFICATIONS

WIDTH	800mm
HEIGHT	800mm
DEPTH	35mm
WEIGHT	11kg

FEATURES

- Copper Free Mirror
- LED Lighting
(Adjustable Colour Temperature)
- Touch Sensor
- Demister with 1 Hour Auto Cut-off
- Bluetooth Speakers

LIGHTING SPECIFICATIONS

CCT	2700K - 6500K
CRI	>80

INSTALLATION

- Wall mount
- Hardwire
- Input voltage: 220-240v 50Hz

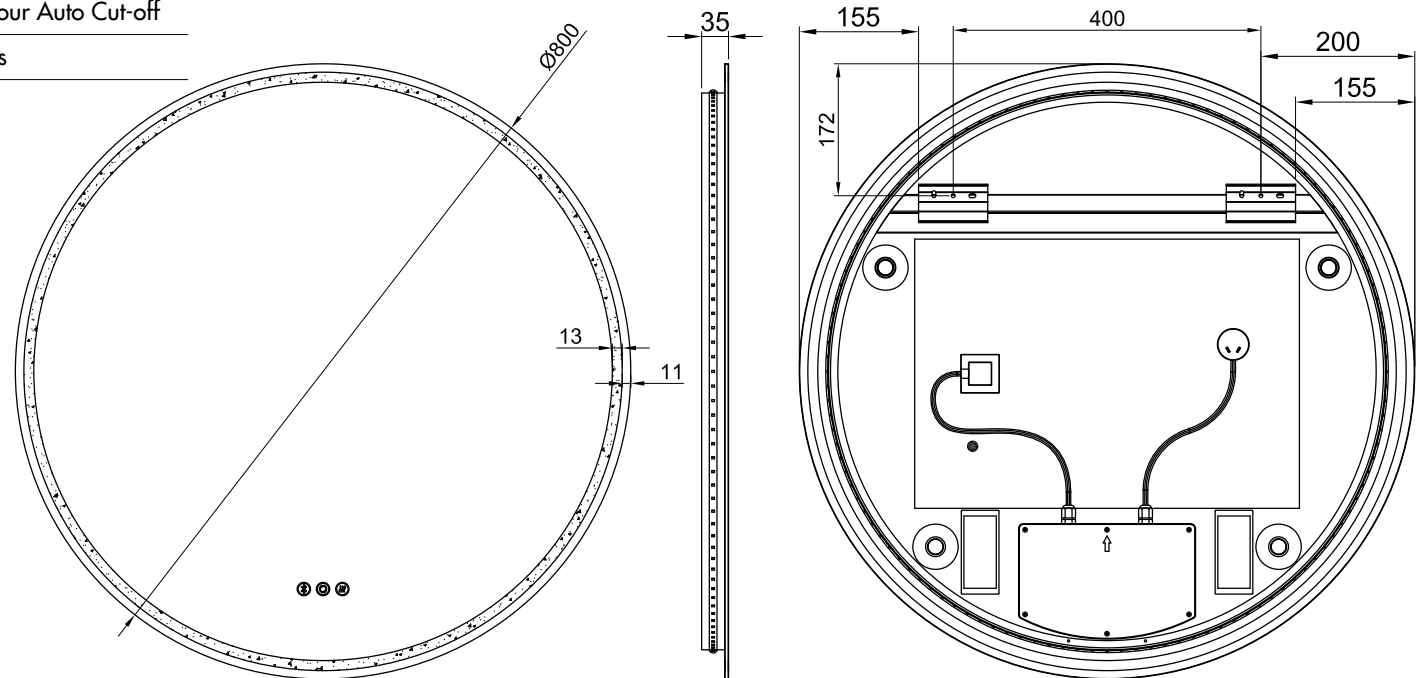

Disclaimer: All LED Products requiring hardwiring must be installed by a licensed electrician in accordance with local regulations. Sizes are in mm and nominal and should be checked prior to installation. Actual colours may vary so please check colour samples before ordering. Installation is acceptance of our products. Installation of faulty, warped, chipped or damaged products will void our warranty.

SPHERE 800DB

PRODUCT CODE

S80DB

LED MIRROR

SPECIFICATIONS

WIDTH	800mm
HEIGHT	800mm
DEPTH	40mm
WEIGHT	11kg

FEATURES

Copper Free Mirror
LED Lighting (Adjustable Colour Temperature)
Backlit
Touch Sensor
Demister with 1 Hour Auto Cut-off
Bluetooth Speakers

LIGHTING SPECIFICATIONS

CCT	2700K - 6500K
CRI	>80

INSTALLATION

Wall mount
Hardwire
Input voltage: 220-240v 50Hz

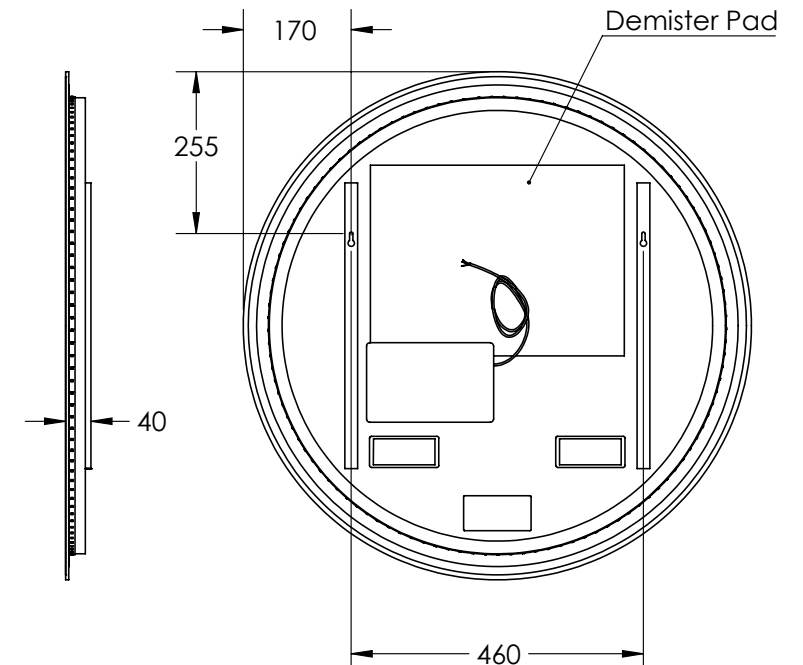
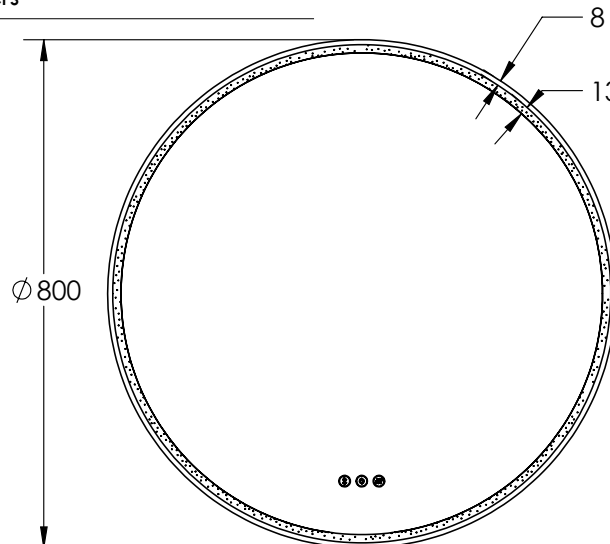

Disclaimer: All LED Products requiring hardwiring must be installed by a licensed electrician in accordance with local regulations. Sizes are in mm and nominal and should be checked prior to installation. Actual colours may vary so please check colour samples before ordering. Installation is acceptance of our products. Installation of faulty, warped, chipped or damaged products will void our warranty.

Please check actual product in box for bracket type used

SPHERE 800DB

LED MIRROR

SPECIFICATIONS

WIDTH	805mm
HEIGHT	805mm
DEPTH	45mm
WEIGHT	11kg

LIGHTING SPECIFICATIONS

CCT	2700K - 6500K
CRI	>80

INSTALLATION

Wall mount
Hardwire
Input voltage: 220-240v 50Hz

FEATURES

Copper Free Mirror
LED Lighting (Adjustable Colour Temperature)
Touch Sensor
Demister with 1 Hour Auto Cut-off
Bluetooth Speakers

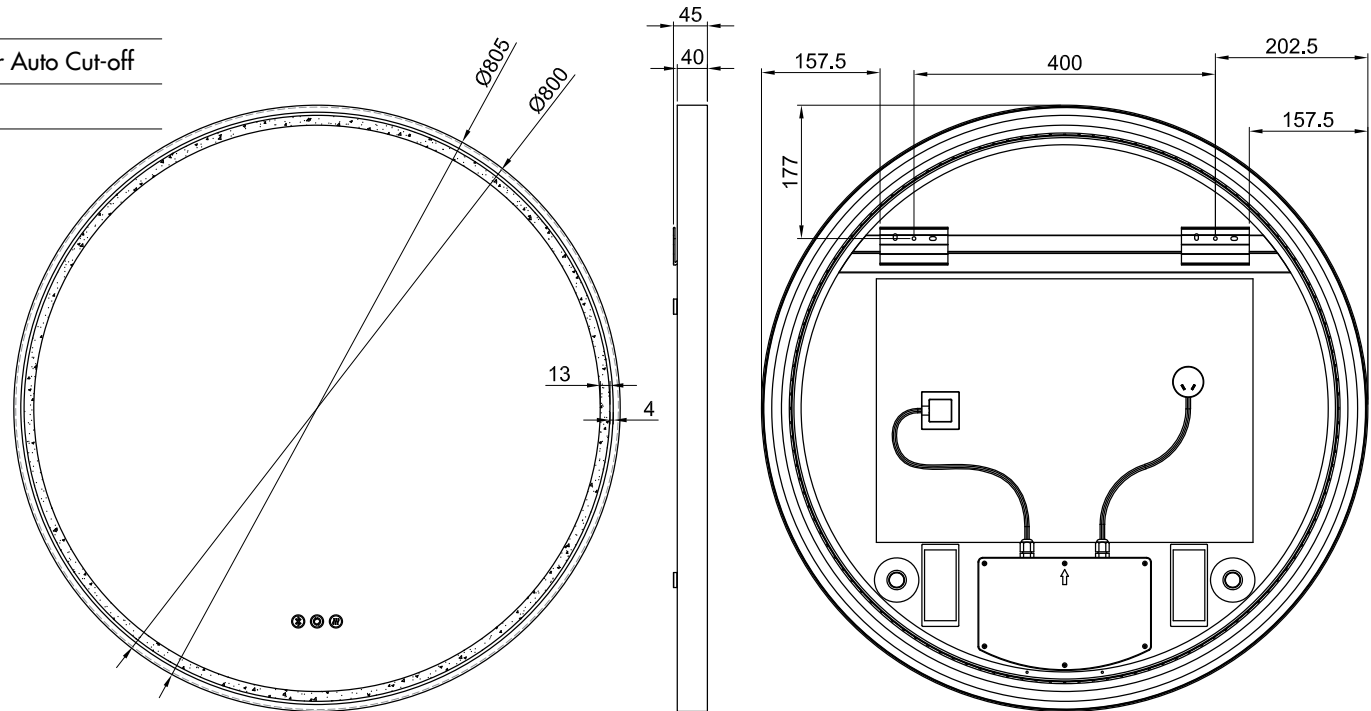

Disclaimer: All LED Products requiring hardwiring must be installed by a licensed electrician in accordance with local regulations. Sizes are in mm and nominal and should be checked prior to installation. Actual colours may vary so please check colour samples before ordering. Installation is acceptance of our products. Installation of faulty, warped, chipped or damaged products will void our warranty.