

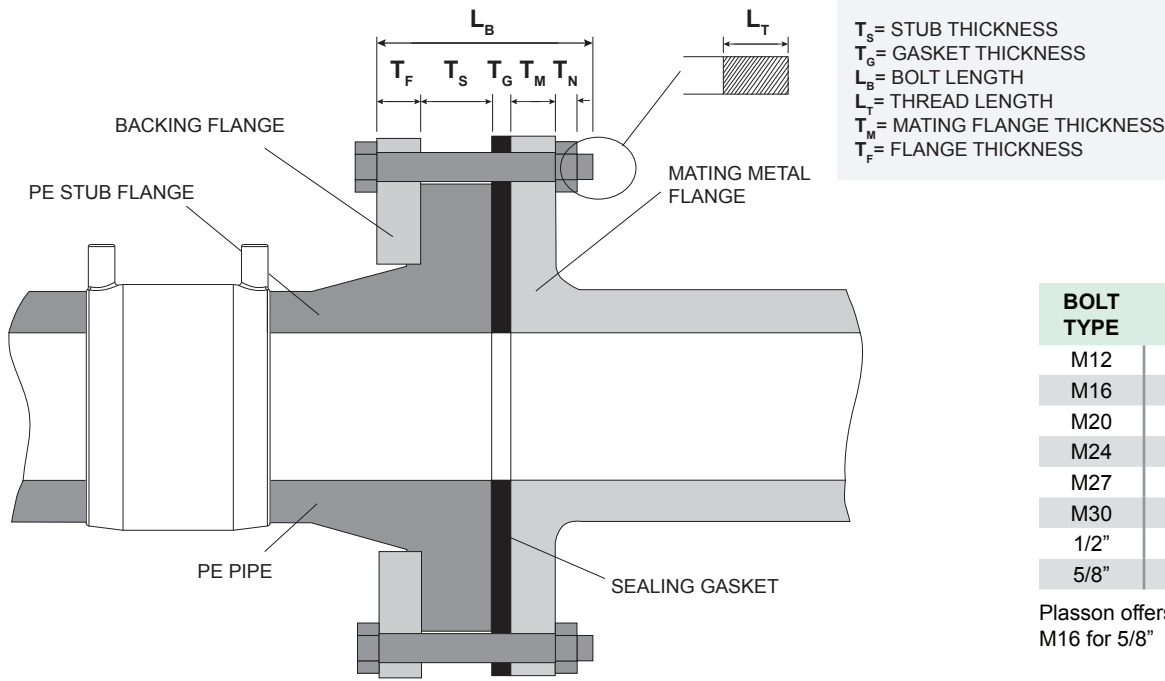

Stub Flange System



| BOLT TYPE | NUT LENGTH | THREAD LENGTH |
|-----------|------------|---------------|
| M12 | 10.8 | 27 |
| M16 | 14.8 | 37 |
| M20 | 18 | 45 |
| M24 | 21.5 | 53.75 |
| M27 | 24 | 60 |
| M30 | 25.6 | 64 |
| 1/2" | 10.8 | 27 |
| 5/8" | 14.8 | 37 |

Plasson offers M12 bolts for 1/2" and M16 for 5/8"

Calculating the required bolt length of a stub flange system is dependent on the dimensions of the components shown in the above picture. This catalogue shows Stub (T_S), Flange (T_F) and Gasket (T_G) thicknesses.

Metric Bolts are used with Table D and E, PN16 and PN21 flanges. These bolts have a fixed thread length and selecting the right length of bolt is important to ensure the nut has sufficient length to tighten the system.

The minimum length of the bolt must be greater than the thickness of all components combined while allowing sufficient thread for the nut to tighten onto.

$$L_B - L_T > T_F + T_S + T_G + T_M$$

The maximum length of the bolt must ensure that the nut doesn't bottom out on the thread of the bolt before sufficiently tightening the system. Usually 1.5x the nut length is allowed for tightening.

$$L_B - (1.5 \times T_N) < T_F + T_S + T_G + T_M$$

Metric Studs are typically used instead of bolts with PN35 flanges. Studs are threaded along the entire length and there is, therefore, no maximum length. The minimum length of the stud is determined by the same method as for bolts.

Lengths listed in this catalogue are theoretical and have not made any provision for system compression or any tolerances. Please consult the relevant standards to ensure that the selected bolts are suitable for your application.

