



Series 1330

Flare x Nut & Tail
AGA Approved
Brass Ball Valve

FEATURES

MANUFACTURED IN ITALY

FULL BORE

AUSTRALIAN GAS ASSOCIATION APPROVAL #5301

AUSTRALIAN PATENT NUMBER 2006200845

FITTED WITH AN INTEGRAL LOOSE NUT & TAIL, MAKING IT IDEAL AS AN ISOLATION VALVE FOR APPLIANCES SUCH AS CONTINUOUS FLOW WATER HEATERS

PTFE GASKET

LOOSE NUT IS PROTECTED BY PLASTIC CAP TO PROTECT GASKET

BLOW-OUT PROOF STEM

MUST BE OPERATED IN FULLY OPEN OR CLOSED POSITION

ALL VALVES PRESSURE TESTED DURING PRODUCTION

SIZE RANGE: 15MM TO 20MM

NOTE: THE VALVE IS ALSO AVAILABLE WITH A 15MM X 20MM CONNECTION

PRESSURE AND TEMPERATURE RATINGS

TEMPERATURE RANGE: -10°C TO 80°C

MAXIMUM OPERATING PRESSURE AT NOMINAL TEMPERATURES: 2100 kPa



AGA 5301
AS 4617

Series 1330

Flare x Nut & Tail AGA Approved

Brass Ball Valve



DIMENSIONAL AND COMPONENT DIAGRAM

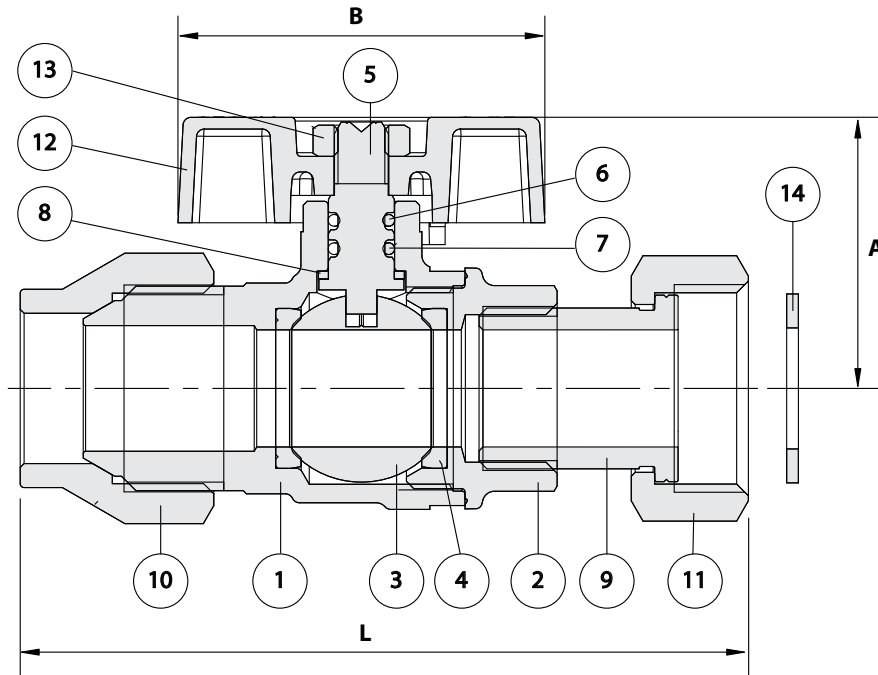

MATERIALS

POS.	PART NAME	MATERIALS
1	BODY	BRASS
2	END ADAPTOR	BRASS
3	BALL	BRASS (CHROME PLATED)
4	SEAL	PTFE
5	STEM	BRASS
6	UPPER O-RING	HNBR
7	LOWER O-RING	EPDM PEROXIDE
8	THRUST WASHER	PTFE
9	TAIL	BRASS
10	NUT	BRASS
11	NUT	BRASS
12	HANDLE	POWDER COATED ALUMINIUM
13	NUT	ZINC PLATED STEEL
14	GASKET	PTFE

DIMENSIONS - mm

Prod. Code	Size	A	B	L	Wgt kg
1330015	15	31	47	83	0.212
1330020	20	35	47	95	0.325
1338015	15x20	31	47	93	0.251