



Series 6302

Press-fit x Nut & Tail
AGA Approved
DZR Brass Ball Valve

FEATURES

MANUFACTURED IN ITALY

AUSTRALIAN GAS ASSOCIATION APPROVAL #5301

PRESS-FIT JOINT COMPLIANT WITH AS 3688

TESTED TO DVGW VP 614

FOR USE WITH VIEGA®, ROTHENBERGER® AND KEMPRESS® V-PROFILE TOOLS ONLY

MUST BE INSTALLED ACCORDING TO ACCOMPANYING INSTRUCTIONS & DESIGN GUIDE

CONICAL PTFE STEM SEALING SYSTEM

BLOW-OUT PROOF STEM

MUST BE OPERATED IN FULLY OPEN OR CLOSED POSITION

ALL VALVES PRESSURE TESTED DURING PRODUCTION

SIZE RANGE: 15x15MM, 15x20MM & 20x20MM

PRESSURE AND TEMPERATURE RATINGS

TEMPERATURE RANGE: -20°C TO 100°C

MAXIMUM OPERATING PRESSURE AT NOMINAL TEMPERATURES: 2100 kPa

ACCORDING TO AS 5601 TABLE 4.1, THE OPERATING PRESSURE OF CONSUMER GAS PIPING SYSTEMS CONTAINING COPPER TUBE IS LIMITED TO 200 kPa



AGA 5301 G
AS 4617

Series 6302

Press-fit x Nut & Tail AGA Approved

DZR Brass Ball Valve

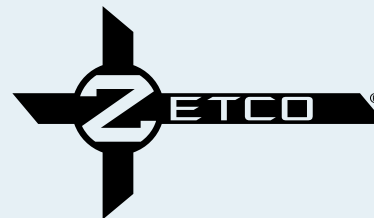

DIMENSIONAL AND COMPONENT DIAGRAM

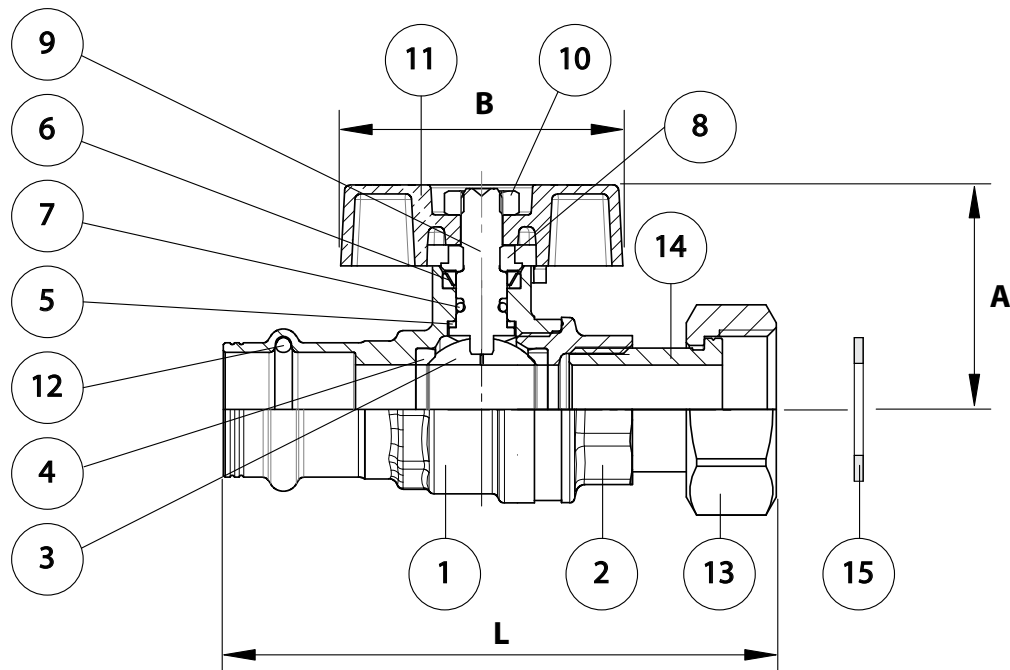

MATERIALS

POS.	PART NAME	MATERIALS
1	BODY	DZR BRASS
2	END ADAPTOR	DZR BRASS
3	BALL	DZR BRASS (CHROME PLATED)
4	SEAL	PTFE
5	THRUST WASHER	PTFE
6	CONICAL SEAL	PTFE
7	O-RING	HNBR
8	GLAND NUT	BRASS
9	STEM	DZR BRASS
10	NUT	ZINC PLATED STEEL
11	HANDLE	POWDER COATED ALUMINIUM
12	O-RING	EPDM PEROXIDE
13	NUT	BRASS
14	TAIL	DZR BRASS
15	GASKET	PTFE

DIMENSIONS - mm

Prod. Code	Size	A	B	L	Wgt kg
6302001	15	37	47	85	0.230
6302002	15x20	45	56	99	0.245
6302003	20	49	56	107	0.268