

PRODUCT INFORMATION

DIMENSIONS

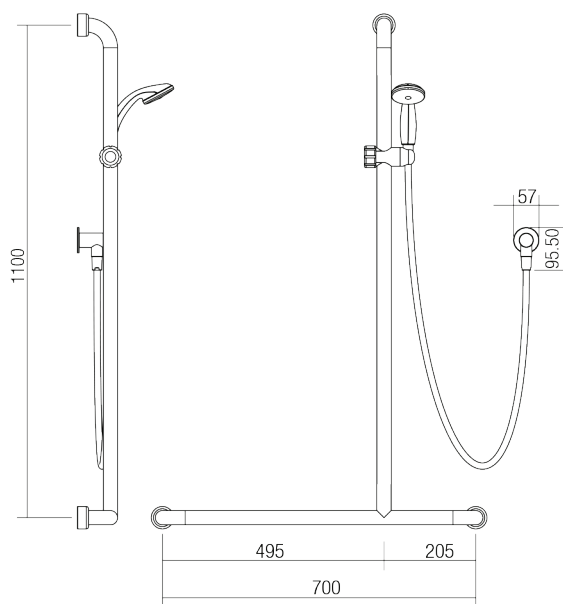

INDICATIVE IMAGE



COMMERCIAL HOSFAB®

Product Code - Finish

- HS 01816 C RH - Chrome

Product Code - Other Finishes

- HS 01816 C LH - Chrome
- HS 01816 C MF - Chrome

Features

- Satin Supreme™ 700 mm x 1100 mm HYGIENIC SEAL® grab rail RH (Right Hand)
- Fabricated from 32 mm 304 stainless steel
- Mount grab rail 800 mm to 810 mm above finished floor level
- ABS Glide Slide handset cradle for handset support and height adjustment
- ABS single function shower with rub-clean spray diffusor
- PVC 1500 mm SOFTFLEX® hose with ½" BSP swivel conical end nut
- DR brass wall outlet elbow with flow INTERCHANGE® spigot
- Brass 57 mm wall flange
- Stainless steel fixings supplied
- Chrome plated finish
- Full pattern spray



- HC 024

Compliance

- Watermark AS/NZS 3662 WMKT 21147
- 3 Star - 9 L/min as per WELS licence number 0046
- Complies with clause 17 of AS 1428.1-2009 for design and construction of grab rails
- Complies with clause 15.5.4 of AS 1428.1-2009 for sanitary facilities



Warranty

See Con-Serv warranty policy for full details.

CON-SERV CORPORATION AUSTRALIA PTY. LTD.
17 Glentanna Street, Kedron · Qld. 4031 Australia

Phone: +61 (0)7 3630 5744 · Fax: +61 (0)7 3630 5755 · Email: mail@con-serv.com.au · www.con-serv.com.au